



# ΣC-2600U DIGITAL SPEAKER PROCESSOR

## User Manual



- > Speaker controller and audio processor
- > 32bits floating-point DSP and digital filter arithmetic
- > Three-way stereo/six-way mono crossover or more kinds of config

---

<b>1.</b>	<b>PRECANTION</b>	<b>1</b>
<b>2.</b>	<b>INTRODUCTION</b>	<b>2</b>
2.1	Audio features	2
2.2	User interface	2
2.3	Other features	2
<b>3.</b>	<b>UNPACKING</b>	<b>3</b>
<b>4.</b>	<b>AC POWER REQUIREMENTS</b>	<b>3</b>
<b>5.</b>	<b>FRONT PANEL CONTROL FEATURES</b>	<b>4</b>
<b>6.</b>	<b>REAR PANEL INTERCONNECT FEATURES</b>	<b>5</b>
<b>7.</b>	<b>DISPLAYS AND OPERATION</b>	<b>6</b>
7.1	Switching display mode	6
7.2	Indications and operations at lock	7
7.3	Display and operation during external control	7
7.4	To recall	7
7.5	Changing remote id	8
<b>8.</b>	<b>BUILT-IN SIGNAL PROCESSING</b>	<b>9</b>
8.1	Input signal selecting block	9
8.2	Mater channel processing block	9
8.3	Output channel processing block	9
<b>9.</b>	<b>SYSTEM CONTROL SOFTWARE</b>	<b>11</b>
9.1	How to get the software	11
9.2	Installing system control software	11
9.3	Connecting DEVICE to a computer	11
9.4	Application of software	12
<b>10.</b>	<b>TROUBLESHOOTING</b>	<b>20</b>
<b>11.</b>	<b>SPECIFICATION</b>	<b>21</b>
<b>12.</b>	<b>INSTALLATION RECORD</b>	<b>22</b>
<b>13.</b>	<b>BLOCK DIAGRAM</b>	<b>24</b>
<b>14.</b>	<b>DIMENSIIONS</b>	<b>24</b>

**ABNORMAL PHENOMENA:**

Please turn off the power and pull out the plug when you find unusual sound or smell when operation.



**POWER CORDS PROTECTION**

Don't touch power cords with wet hands to avoid electric shock.  
Don't put the cords in crowded people.

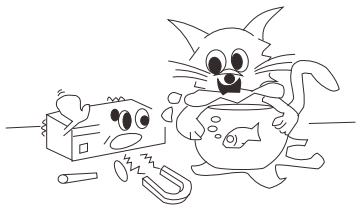

**KEEP AWAY FROM WATER AND SUNDRY GOODS**



**DON'T OPEN THE COVER IF NOT GUIDED BY A QUALIFIED ELECTRICIAN**

**PULL OUT THE POWER CORDS TO AVOID FIRE WHEN YOU DON'T USE THIS UNIT.**

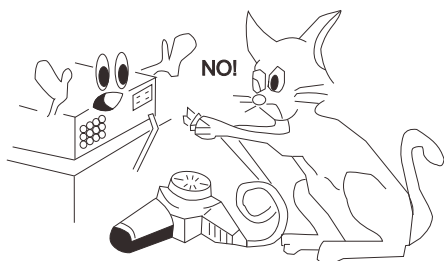
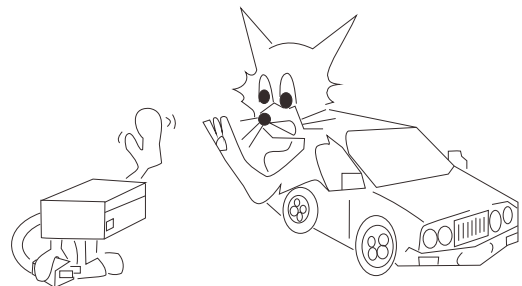

**DON'T OVERLOAD IT**

Thank you for your purchasing of the DEVICE digital speaker processor. This processor builds on the advanced and experienced ideas of design and marketing, the excellent audio performance and competitive quality/price ratio make sure your interests.

This unit DEVICE , can provide two channel analog precise signal the precise digital control. She has audio processor and audio management functions. It can be used to the middle/small sound reinforcement system. And can be used a monitor to monitor to monitor the working issues. RS-485 PC port is provided for use with proper software system. So it is fit for the large avenue systems. The front panel interface allows quick access to all parameter by indication functions: Full control is also available via MIDI input and output jacks. Also indicate each channel configure information (Sound resource, subwoofer, low frequency, middle frequency and high frequency). Numeral remote ID or current users serial number. Setting ID or transfer user's program is available by touching front panel buttons.

### 2.1 Audio Features

The DEVICE utilizes state of the art DSP technologies, beginning with 24bits, 64kHz delta-sigma A/D converters, with 32 bits floating points DSP. Digital processing includes Gain, Polarity Invert, Parametric EQ, Shelving Filters, Time Delay, Crossover Functions (Butter worth/Bessel/Linwitz), Compression, Limiting, and Signal Routing. All inputs and outputs are precision balanced and RF protected using standard XLR connectors.

### 2.2 User Interface

Front panel interface:

LED dynamic indicate, Limiting function indication, Users Program configure indication. Mute input/output indication button, Current program number and Unit ID indication. Front panel operation/running, and Remote ID Changing function button.

Control system software:

The computer interface uses SYSTEM SOFTWARE for Windows98, which allows complete PC control through an USB serial port. The system software is supplied with each unit, or can be downloaded at no cost from the web site. Advantages of using the software include greater preset capacity, and a very intuitive visual representation of the audio routing and control process.

### 2.3 Other Features

Having 50 groups of configure programs, and accessory with audio equipment.

As a part of our system of quality control, every product is carefully inspected before leaving the factory to ensure flawless appearance. After unpacking, please inspect for any physical damage. Save the shipping carton and all packing materials, as they were carefully designed to minimize the possibility of transportation damage should the unit again require packing and shipping. In the event that damage has occurred, immediately notify your dealer so that a written claim to cover the damages can be initiated. The right to any claim against a public carrier can be forfeited if the carrier is not notified promptly and if the shipping carton and packing materials are not available for inspection by the carrier. Save all packing materials until the claim has been settled.

### 4> AC POWER REQUIREMENTS

**Note:**

The 115V/230V switch is built in the DEVICE to avoid damage caused by wrong operation. The default set is 230V before leaving factory. If the local voltage is 115V, please open the cover and set the switch at 110V under disconnecting the ac. If the fuse is damaged, please replace the same type and rating fuse.

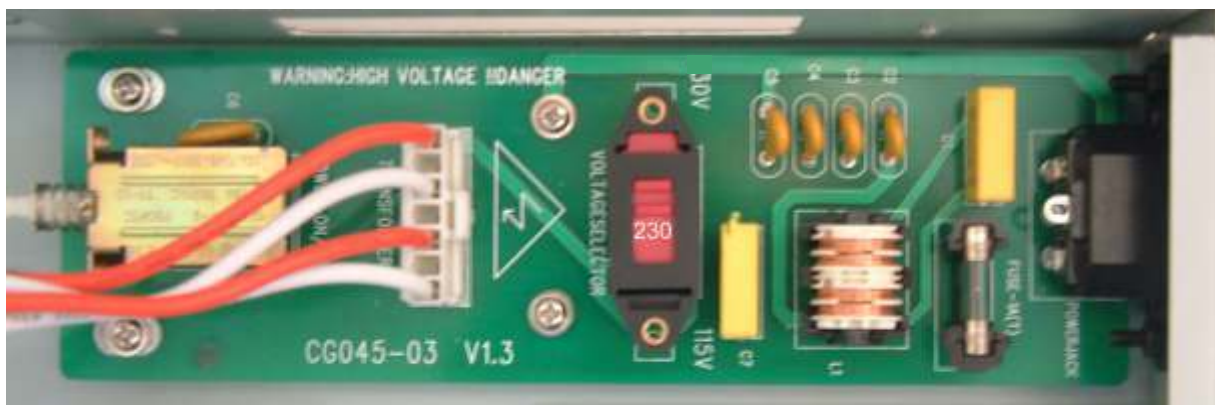

**Instruction:**

The show on the switch is standard. As above diagram, the show is 230V on switch, it means the current ac voltage is 230V.

**Note:**

When the operation on front panel is locked(the LOCK indicator lights up ) or when connecting with PC, all the buttons is not available.

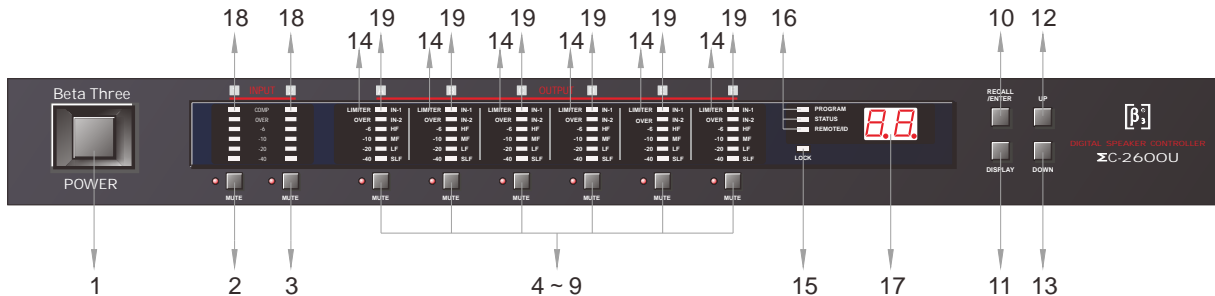

**1. Power switch**

To turn the power on/off. When the unit is turned on, the previous signal setting is recalled.

**2. Input channel 1 mute button:**

Press the button, the red LED on the left lights up, the input is muted. The output from Channel 1 has not the signal output, but at the same time, input level dynamic range still shows the real input status.

**3. Input channel 2 mute button:**

Press the button, the red LED on the left lights up, the input is muted. The output from Channel 2 has not the signal output, but at the same time, input level dynamic range still shows the real input status.

**4-9. Output channel mute button:**

press the button, the red LED on the left lights up, the output is muted, A-F channel have not output, and the level dynamic range LED will be off.

**10. Enter/recall button**

When the " ROGRAM " indicator lights up, press the " ENTER/RECALL " , number display shows the current program number, output channel LED show the channel status. Use the " UP " and " DOWN " buttons to find the needed program, press the " ENTER " button and recall the program.If you want to cancel the recalling, press " DISPLAY " button under the sparkling status.

**11. Display button**

**12. UP button**

**13. DOWN button**

**14. Output channel peak limiter indicator**

**15. Front panel lock indicator**

**16. Status indicator**

**17. Program number or ID number display**

**18. Input channel level dynamic indicator**

**19. Output channel level dynamic indicator**

**Remarks:**

Unit of level indicator

OVER:

lights up when the wave reaches digital's full scale(the clipping level). You need to lower the level when it lights up often.

-6,-10,-20,-40:

Indicates the level in decibels(0dBFS) on digital full scale.

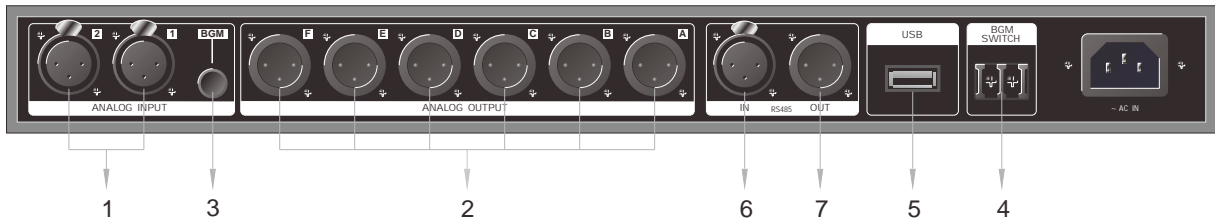

**1. Analog input terminals(IN-1,IN-2)**

Connector: XLR-3-31

1 : GND , 2 : HOT , 3 : COLD

Circuit: Electronic balanced circuit

Maximum input level:+20dBu



**5. Control interface**

(standard USB port; support USB2.0)

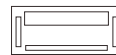

**2. Analog output terminal (A.B.C.D.E.F)**

Connector: XLR-3-32

1: GND, 2: HOT, 3: COLD

Circuit: Electronic balanced circuit

Maximum input level:+20dBu



**6. Remote control input terminal (RS-485)**



1 GND  
2 A+  
3 B-

**3. Spare signal input terminal(BGM)**

Connector: 6.35 big three cores jack



1: GND, 2: HOT, 3: COLD

**7. Remote control output terminal (RS-485)**



1 GND  
2 A+  
3 B-

**4. Spare signal switch(BGM SWITCH)**

Control voltage:DC+5V--+48V

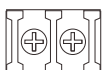

Connecting: terminal board, tight the screw

Action status: the voltage on two terminals > 5V DC, input switch to BGM, or the In1 and IN2 area available

**8. Power input terminal**

input voltage: Refer to 4





**7.1 Switching display mode**

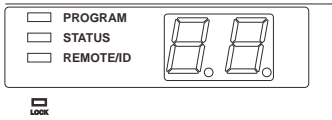

You can change the display mode by pressing the display button in turn. The Display mode indicator shows the current display.(Not available during external control)

When PROGRAM is lit:

The number display indicates the current program number and each output channel indicator indicates output level at that output;

When OUTPUT STATUS is lit:

The number display indicates the current program number and each output channel indicator indicates output assignment status.

When REMOTE/ID is lit:

The number display indicators REMOTE ID number and each output channel indicator indicates the level.

Output level indication:

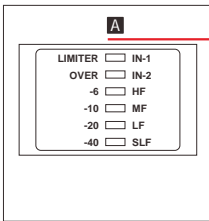

Indicates signal levels of each output after all signal processing. Output level correspond to the level scale printed at the left side of the indicator. When OVER is lit for a long time: means that the signal is too big, can lower the input signal; When LIMITER is lit: means the compressor is working.

Output status indications:

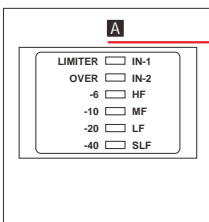

Indicates simply which output channel is fed by which input channel and the output frequency range based on the setting of filter cut-off frequencies. This function helps prevent speaker from being damaged as you can make sure of each output's status when you operate RECALL or connect an amplifier and loudspeaker. The print at the right side of the LED show each indication's meaning as follows:

" IN-1,IN-2 "

Indicates which input's signal is the sound source. When both indicators light up, it indicates monomixed signal is the sound source.

" HF,MF,LF,SLF "

Indicates the frequency range of each output channel:

- HF : High Frequency; Lights up when frequencies >=1KHz;
- MF : Middle Frequency; Lights up when frequencies from 500Hz to 1KHz;
- LF : Low Frequency. Lights up when frequencies from 100Hz to 500Hz;
- SLF: Super Low Frequency; Lights up when frequencies <=100Hz.



## 7.2 Indications and operation at LOCK

To assure the use security by using an external computer(need to install control software of this processor), you can disable RECALL and REMOTE/ID operation with the unit, and then LOCK indicator lights up.

You can operate without using an external computer to LOCK and release LOCK of the unit

To LOCK

- 1). Turn off the power,
- 2). Turn on the power with keeping pressing UP button.(Sound is not output),
- 3). LOCK lights up while digital transistor display normal No., move away your hand from UP ,  
Auto panel operation is prohibited and come to normal working status.

To release LOCK

- 1). Turn off the power
- 2). Turn on the power with pressing DOWN button.
- 3). LOCK lights down while digital transistor display normal No., move away your hand from DOWN, Auto panel operation open and come to normal working status.

## 7.3 Display and operation during linking to computer

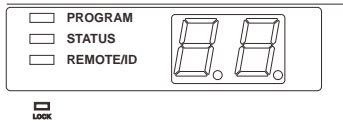

You cannot use buttons on the front panel while you control with an external computer. In this case, indicator of LOCK at DISPLAY mode indicator light up. The number of the display indicates the current program number.

## 7.4 " RECALL " : Transferring program

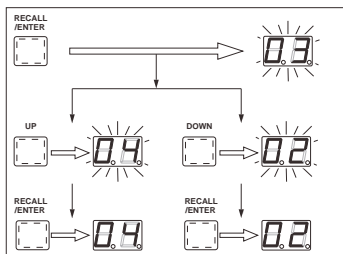

RECALL of stored programs with the unit is as follows,

- 1). Press RECALL/ENTER button while while PROGRAM indicator lights up. Then the currently set program number flashes and each output channel indicator turns to flash simultaneously, meaning that it is ready for setting output status.(Program will not be changed until step 3),
- 2). Select program number you to RECALL output indicating the program arrangement information with UP and DOWN,
- 3). Press RECALL/ENTER button.The program number will stop flashing and display the newest programs' Number.

### Attention:

- 1). You can press DISPLAY button to cancel while digital transistors display, the mode will be back to the normal status before starting RECALL,
- 2). Program NO. inside without save will not display,
- 3). RECALL operation is impossible if you press RECALL/ENTER when there is no RECALL-capable program.  
Also, any stored programs which are set RECALL LOCK are never displayed. (use an external computer to set and release RECALL LOCK.),
- 4). When the LOCK indicator is lit, RECALL operation is impossible.

### 7.5 Changing remote ID

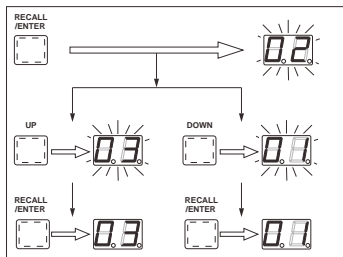

REMOTE ID is preset at factory to 01. It can only be changed by operating from the panel:

- 1). Press DISPLAY button. Then REMOTE/ID indicator lights up and currently selected number displays set number displays,
- 2). Press UP or DOWN button repeatedly until the number you want appears. When you keep pressing them. The number gains or loses continuously,
- 3). Press " RECALL/ENTER " button, confirm the changing and display the latest ID code.

Signal Processing Block and procedure Chart ( go to 13 for reference).

### 8.1 input signal selecting block

Select the combination of 2 analog channels ( IN1+IN2) and 2 digital channels ( IN1,IN2).

### 8.2 Master channel processing block

#### 1). 11-band parametric equalizer

EQ Type : (parametric equalizer type): Select one of Peaking/ bandpass/hi-shelf/lo-shelf/notch;

Frequency : Adjustable in a range of 20Hz-20kHz, at 1/12 oct steps and from 121 points.

Level : As for peaking and shelving, adjustable in a range of + 12.0dB and at 0.5dB steps.

Q : As for peaking, bandbass and notch, adjustable in 73 levels in a range of Q =0.31-19.4

Gain : Ajustable in a range of oo + 12.0dB at 0.5dB steps;

PEQ Link : You can link IN1 & IN2 by linking command, and adjust and influenced PEQ & Gain.

#### 2). Master channel delay compressor

Can be adjusted with 15.515  $\mu$  sec steps up to 0-2.034 seconds.(15.515  $\mu$  sec is equal to sound transfers to 5.275mm in air)

### 8.3 Output channel processing block

Each output channel is identical and can to be set independently.

#### 1). Selecting the input signal

You can select the input source from master 2 channels from following 3 patterns.

IN-1 : Master IN-1 channel signal

IN-2 : Master IN-2 channel signal

IN-1+ IN-2 : Mono-mix signal of master 2 channels

#### 2). Crossover filter (LCF,HCF)

Selectable OFF for both LCF and HCF. Also it allows to be used for a 2input/6output signal Distributor.

Frequency: Adjustable in a range of 20-20kHz, at 1/12 oct steps and from 121 points.

Filter type:

- (1) <sup>2</sup>nd order Butterworth(-12dB/oct slope)
- (2) <sup>3</sup>rd order Butterworth(-18dB/oct slope)
- (3) <sup>4</sup>th order Butterworth(-24dB/oct slope)
- (4) <sup>5</sup>th order Butterworth(-30dB/oct slope)
- (5) <sup>6</sup>th order Butterworth(-36dB/oct slope)
- (6) <sup>2</sup>th order Bessel(-12dB/oct slope)
- (7) <sup>3</sup>th order Bessel(-18dB/oct slope)
- (8) <sup>4</sup>th order Bessel(-24dB/oct slope)
- (9) <sup>5</sup>th order Bessel(-30dB/oct slope)
- (10) <sup>6</sup>th order Bessel(-36dB/oct slope)
- (11) <sup>2</sup>th order Linkwitz-Riley(-12dB/oct slope)
- (12) <sup>4</sup>th order Linkwitz-Riley(-12dB/oct slope)

**3). 3-band PEQ**

It offers 3-band PEQ for each output channel.

Each parameter of 3-band PEQ is same as the PEQ of master channel processing block.

**4). Channel Level**

Adjustable in 0.5dB steps over a range of  $\infty$  -- +12.0dB.

**5). Peak Limiter.**

Include Instantaneous waveform transformation type peak limiter in each channel. It can be set over a range of -24.0dBFs+2dBFs, OFF at 0.5dB steps. When signal reaches the limiting level, the limiter indicator is lit.

Following is the chart before processing (narrow line) and after processing (wide line).

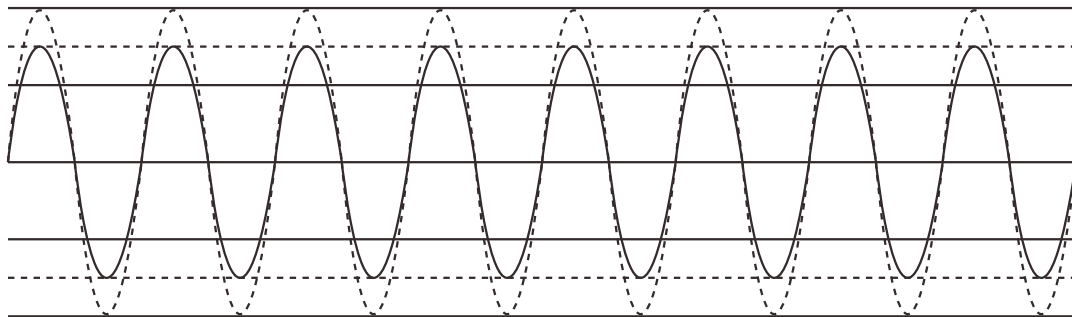

Real line: before processing Broken line: after processing

**6). DELAY**

Capable adjust with 15.515  $\mu$  sec steps at 0- 2.034seconds ( 15.515  $\mu$  sec is equivalent to approximately 5.275mm in the speed of sound.

**NOTE:**

The minimum delay time between input and output while using an analog input/output is about 1.2msend when delay time is set at 0. This delay is caused by signal's passing through A/D, D/A converter and the signal processor.

**7). Phase**

Capable of switching normal or inverse (180 °).

**8). Muting**

Capable of setting for each channel.

**9). Domain of output channel link**

Except Muting and source of invoice is individual setting everlasting, Parameter of other channels can be adjustable by link.

This facility offers a multi-functional software control panel, which controls Max 50 equipments, and it equips lots of relative documents and allow users to put into practice concretely and quickly.

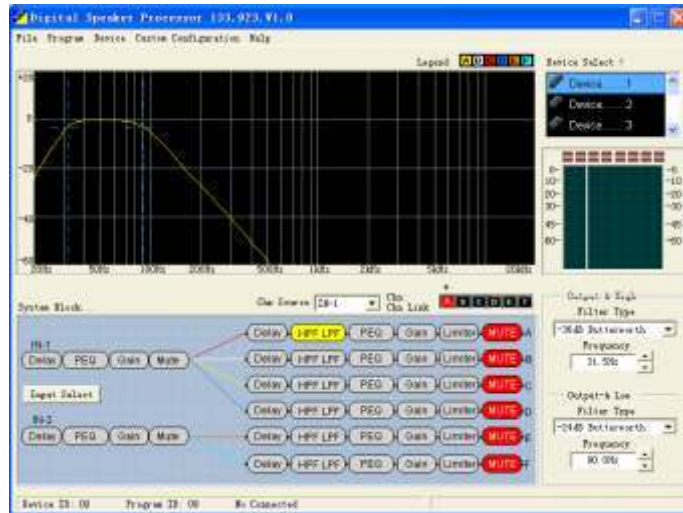

**9.1 How to get this software**

The software is stored in the disc. of course, you can also down load the latest version of this software and more our company's optimize collocated files and practical useness.

**9.2 Installation of the software**

System requirement: Window98 or above operation systems. Distinguish of clearance at 800\*600 or above, have at least a USB serial interface . Play the installation program DEVICE on the disc, and finish the steps of the instruction installation procedures

**9.3 Facility and the connection of computer**

System demand: Windows98 operation systems or above, Distinguish of clearance at 800\*600 or above. Have at least a USB serial port . Play the installation systems DEVICE on the disc, and finish the steps of the instruction installation procedures.

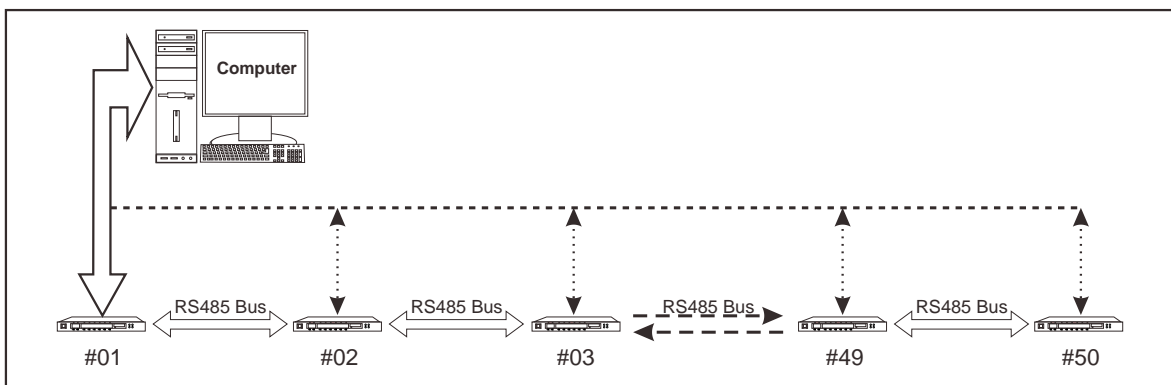

Use a computer installing control software , then it can control the facilities on RS485, and by USB which can connect into any facility on the net( The connecting facility to computer play the role as the general line of transistors of USB and RS485.

9.4 Using of the software

When you finish the installation , run the controlling software and it will display the following page:

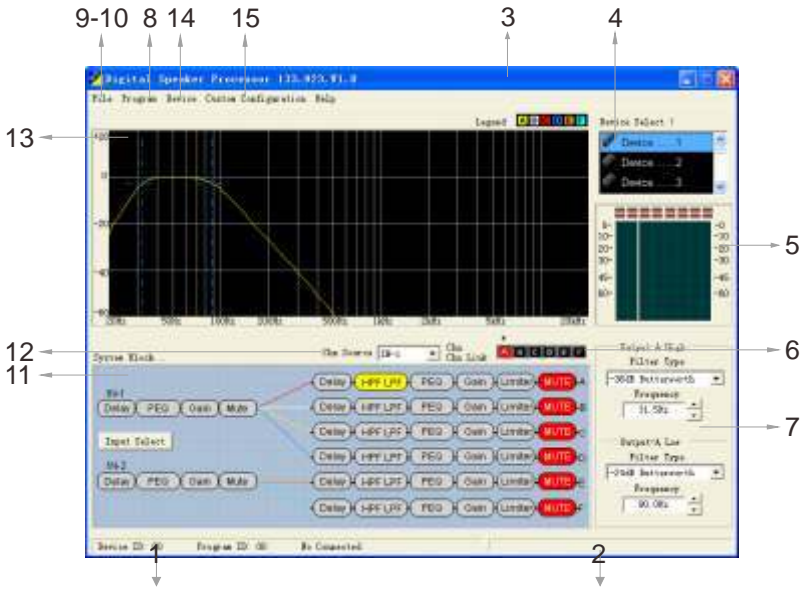

- 1). Display of status: Device ID, Program ID, Serial Port,
- 2). Indication of communication between this facility and computer: It displays OK normal communication, or ERROR for unnormal,
- 3). By different colors to identify the 13th curve of frequency response,
- 4). Device list, 2 times press No. of the device , then being ready to connect, and display the following interface:



If online, press this device then show the "Disconnect with this device" information to process offline command.

[ Before connect, there have two option: Download data from PC to DEVICE---Indicate that download data have configured in computer, But only load into RAM. If to save datas, you should process the save operation(in Program menu); Upload data from DEVICE to PC indicate that load the current program using in device into PC to review or edit ]

- 5). Input channels IN1, IN2 and output channels OUT-A, B ,C D,E,F indication of electric level,
- 6). Indicate the currently adjustable output channels( \*marks) and connection status among all channels , one time press this area,
- 7). Parameters' adjustable areas, different parameters to different adjustable methods/types,

- 8). Program Operation Menu (effective only on line), after click, if choose " program List " order, then you can see the following interface:

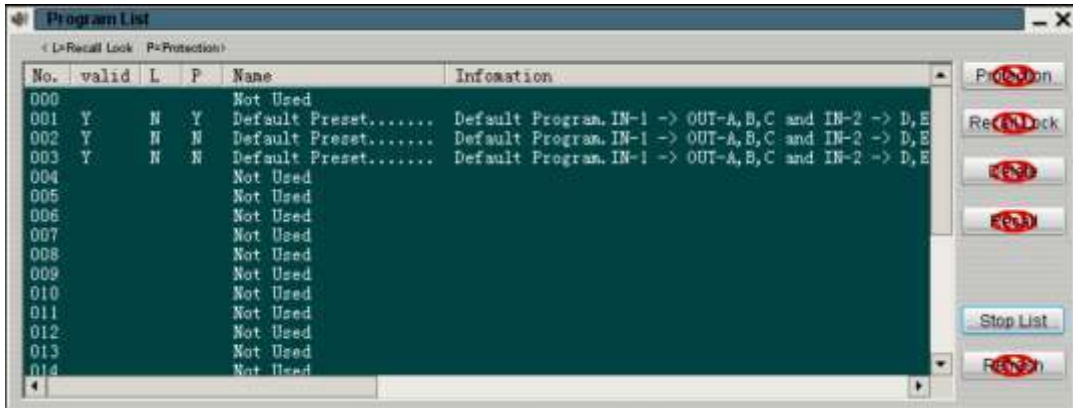

after listing(Press " Stop List " during the listing, the Program List will end )show:



Press " Confirm " , then Show:

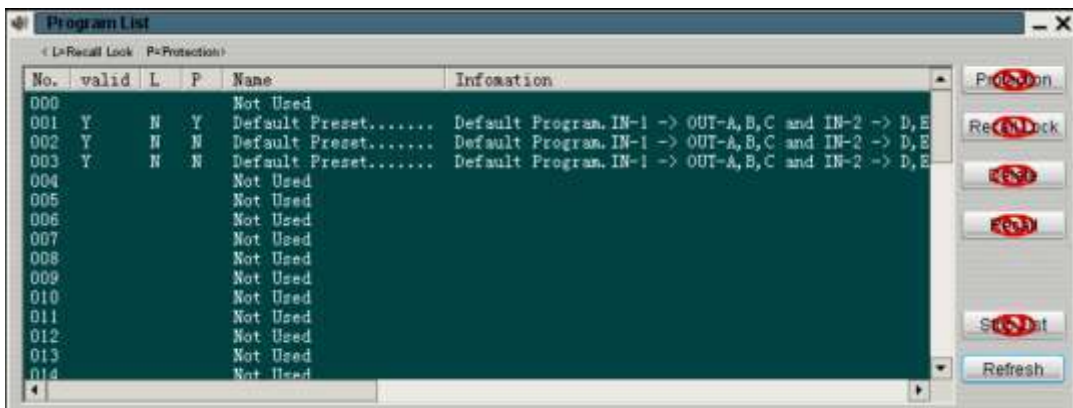

Red Marks on the right of button, Show no operation.

Protection: If set " Protection " ,the program can not be revised or covered.



Recall Lock: Prohibit/ Permit to transfer the program via the panel key, if set " rohibit " ,you can not see the program on the Panel ,and even can not transfer the program..



Delete: the program protected will not be deleted

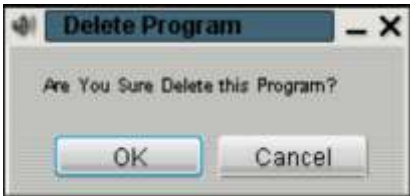

Recall: Press the " Recall " order, will implement the operation of Transferring Program, and set the choosing program as the current using program.

Stop List: Stop List Order only will be used in implementing List Program.

Refresh: Refresh Order only will be used in after List Program ending.

If choosing " Program Restore " order :

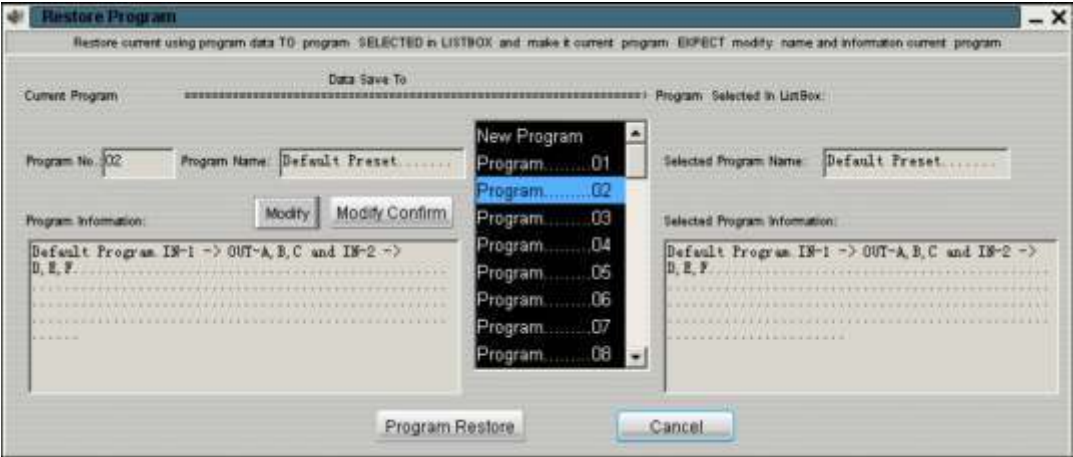

Save the current program to program number designated, if choosing the New Program ,and automatically use the new program number ,which is not being used, or otherwise save to program number designated. You may press " Modify " to revise the program name and program information , and enter the contents in the Program Name column and Program Information Column respectively , after finishing, please press " Modify Confirm " to save.



9). Save the current configuration program to file, and click to show the following interface:

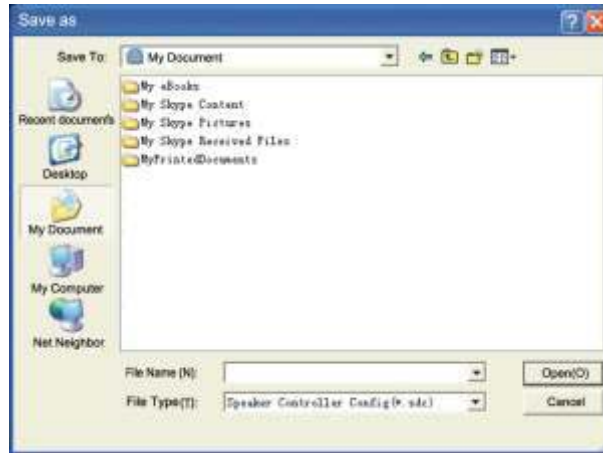

10). Open the program file in the computer, and click to show the following interface:

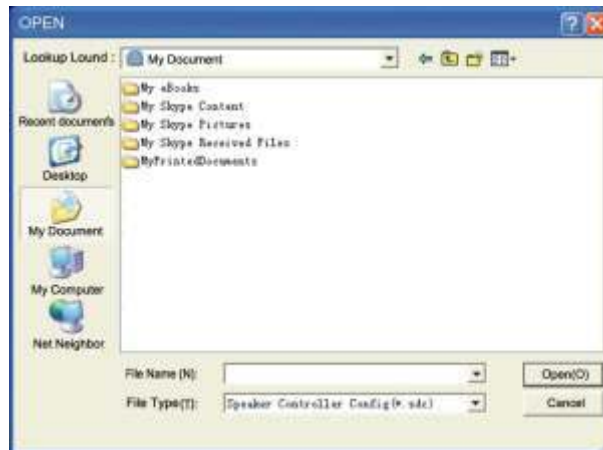

Choose the file, and press " Open Button "

11). Signal processing procedure ,Function Module, Parameter Adjustment range  
11.1 Enter mode choosing: (1) analog 2 Channel (2) Analog Mono Mix: IN1+IN2



11.2 Delay Adjustment Interface

Right corner is the Delay Adjustment Interface, if change the delay time, and the interface shows the delay distance accordingly(Sound speed=340m/s).

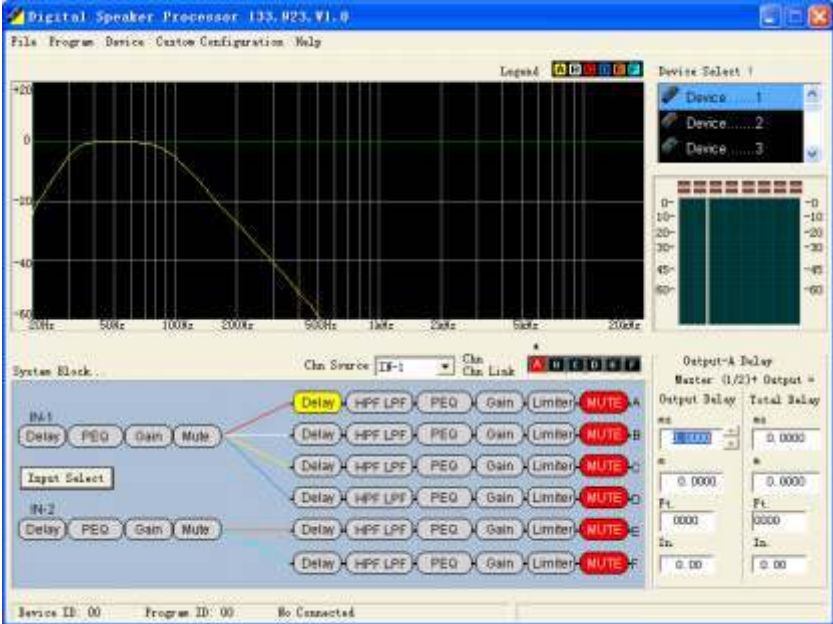

11.3 PEQ Adjustment Interface

You can set PEQ Open/ Close and Link  
**Attention: Link setting is also effective to Enter Channel Gain.**

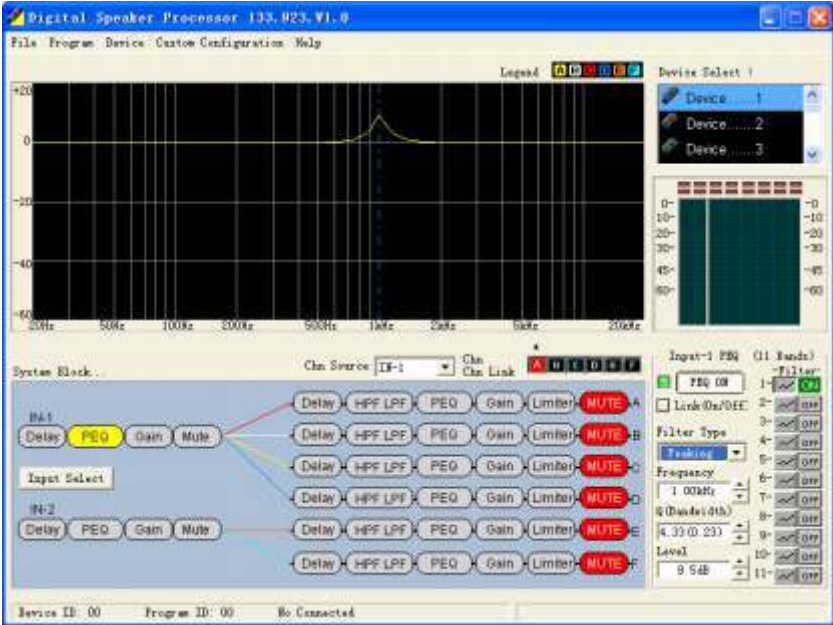

Only press the button ,which show the Filter Curve accordingly, you can adjust the parameter ( Filter Tyye, Central Frequency,Q/Bandwidth, Gain/Level).

11.4 Input Channel Gain Adjustment Interface:

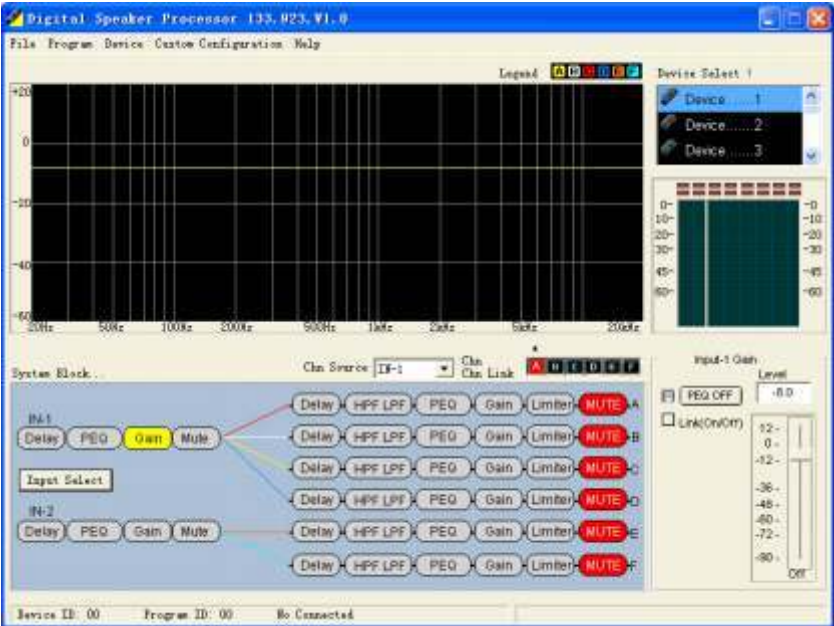

11.5 Input Channel Silence , press " Mute " , and turn red to show the state of Mute, otherwise , it is no Mute.

11.6 Output Channel Crossover setting Interface:

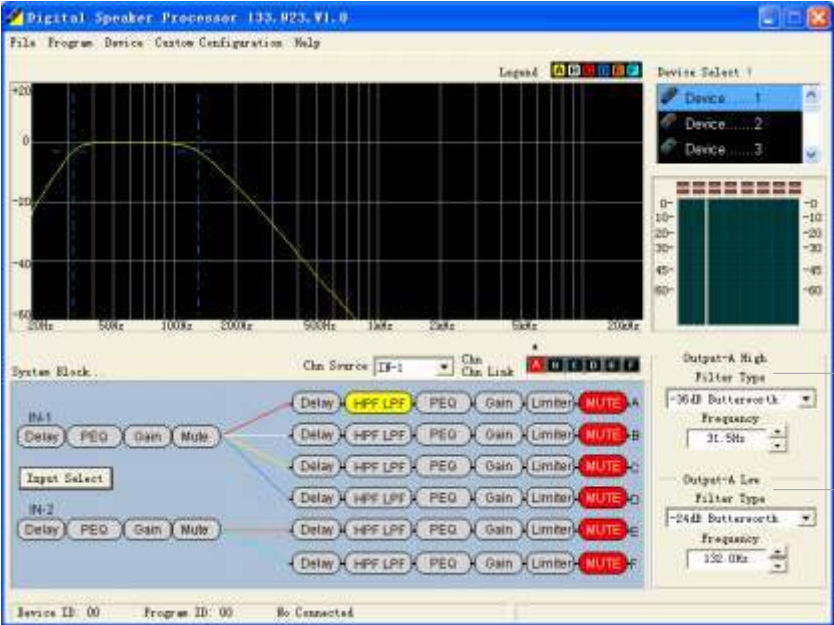

The above part is High Pass Filter ( cut low frequency), the under part is Low Pass Filter (cut high frequency ).

11.7 Output Channel Peak Limit Adjustment Interface  
Adjustment Range :-24.0db ~ +2.0db,OFF, 0.5db for each step.

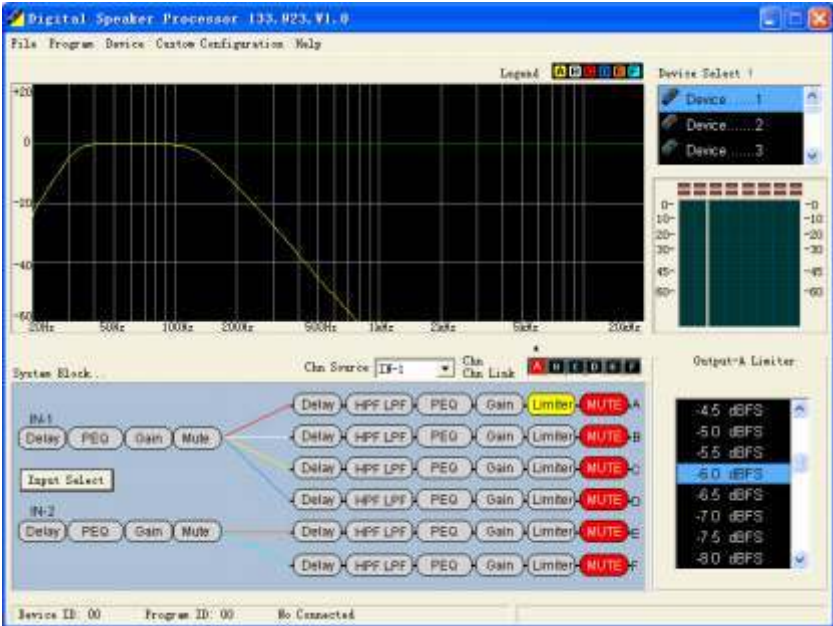

11.8 Output Channel " Mute " ,setting same as the INPUT CHANNEL.

- 12). Current output channel sound source choosing ( Choosing IN-1,IN-2,OR IN-1+IN-2)
- 13). Frequency Response Curve showing range, Show the PEQ curve of the main channel IN-1,IN-2 and the Output Channel, and the curve of the HPF / LPF .
- 14). Click the button with mouse and then show the following interface.

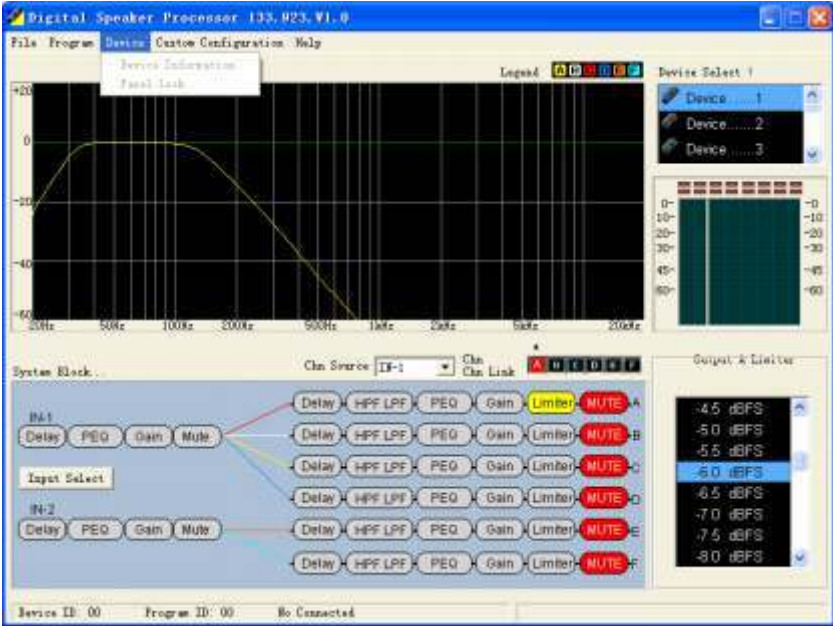

15). Default configure adjustment: when it is in the off line status, click the button for showing the following interface:

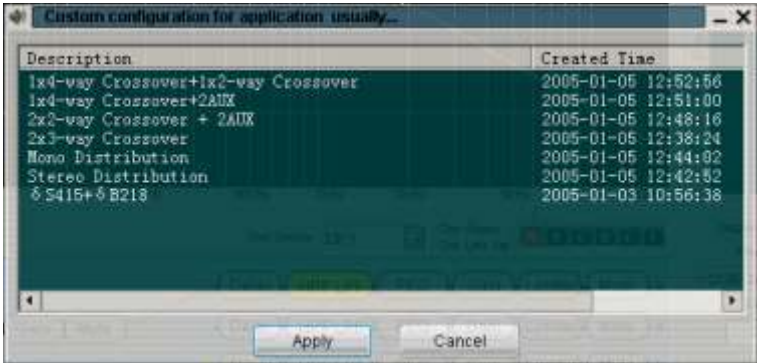

Select the default configure file which need to adjust, click  , for returning to the main interface. At the time, the parameter of the controller did not change. Click the command for login. Select download configure to controller. The parameter of controller will update after successful login, Audio process will be effective. Please check the other relevant illustration of further operation.

**10.1 Audio relevant question**

Disconnect :	Check the power cord is connected well or not? And the power button on the front panel is turn on or not?
Panel button	Check the lock button on the panel is flashing or not. And unit is locked status or not.
No Sound output :	Check the input/output is silent or not? The plus of input/output is weak or not? Check the selection sound source of each output channel. And confirm whether have signal to relevant input channel. If finished setting the crossover, confirm the closed frequency of high filter is lower than the closed frequency of low filter.
Overload indicator is flashing often :	Whether the input signal is over strong? (The max input signal is over 20dBu or not?). Whether the plus of Input/output increased much? Check the plus of parameter increased much.
Sound default :	Check the crossover setting if want output full range signal.
Noise :	Check whether the setting of input signal and plus is limited. And will get more plus from output. So do not try to adjust much the plus of the equipment and filter. That will caused the output noise being strong.

**10.2 RS-232/RS-485 connecting problem**

- 1). Check all the connecting wires, and make sure these are standard wires. Please check the back plate connecting terminal definition for the reference of connecting standard.
- 2). While many machines are connected with the head line(485), Please check the address pins of the machines, and make sure no conflict.
- 3). Check the USB port, Keep the hardware and software are in the same port.

**10.3 BGM switch problem**

- 1). Make sure BGM switch controlling terminal is connected well.
- 2). Make sure BGM switch controlling signal(difference between two lines) are between +5VDC---+48VDC.

**Analog input**

Port	:	Balanceable 6.35 mike socket (BGM signal) and XLR-3-31 input socket
Input impedance	:	10k
Max input power	:	+20dBu
A/D conversion	:	Frequency 64kHz, 24bits

**Analog output**

Port	:	Balanceable XLR-3-32 output socket
Output impedance	:	47
Load impedance	:	600
Max output level	:	+20dBu

**Analog characteristics**

Frequency response	:	20Hz-20kHz(+0.3/-0.3dB), 10Hz-30kHz(+0.3/-3.0dB)
S/N Ratio	:	110dB(A Weight)
Distortion+noise	:	<0.006%
System min delay	:	1.2ms(signal output and input setting are "0".)
Remote control port	:	Please check"computer control soft/hard ware ports"

**Others**

Power request	:	AC 110V-120V~, 50/60Hz
Power waste	:	25W
Dimension	:	482X44.8X228mm(WXHxD)
Weight	:	4.7Kg
Usage temperature	:	0-+40
Storage temperature	:	-10-+60

**Accessories**

Power cord	:	1 pcs
USB connector	:	1 pcs
Fuse(spare)	:	500mA/125VAC delay/250mA/250VAC delay
User manual	:	1 pcs
Disc	:	Including user manual, installation software etc.

Installation record : \_\_\_\_\_ Worker : \_\_\_\_\_ Tel: \_\_\_\_\_ E-mail: \_\_\_\_\_

Agent : \_\_\_\_\_ Address : \_\_\_\_\_

System description(equipment, engineer request and its relevant information): \_\_\_\_\_

\_\_\_\_\_  
 \_\_\_\_\_  
 \_\_\_\_\_

DEVICE program No.: \_\_\_\_\_ program name : \_\_\_\_\_

program panel is locked or not: \_\_\_\_\_

program information: \_\_\_\_\_

input selection:  stereo,  mono :

input channel1: Plus \_\_\_ dB, delay \_\_\_ ms, sound silence  on  off, channel click status  on  off

parameter equal filter 1,	filter type _____	centre frequency _____	Q value/wide _____
parameter equal filter 2,	filter type _____	centre frequency _____	Q value/wide _____
parameter equal filter 3,	filter type _____	centre frequency _____	Q value/wide _____
parameter equal filter 4,	filter type _____	centre frequency _____	Q value/wide _____
parameter equal filter 5,	filter type _____	centre frequency _____	Q value/wide _____
parameter equal filter 6,	filter type _____	centre frequency _____	Q value/wide _____
parameter equal filter 7,	filter type _____	centre frequency _____	Q value/wide _____
parameter equal filter 8,	filter type _____	centre frequency _____	Q value/wide _____
parameter equal filter 9,	filter type _____	centre frequency _____	Q value/wide _____
parameter equal filter 10,	filter type _____	centre frequency _____	Q value/wide _____
parameter equal filter 11,	filter type _____	centre frequency _____	Q value/wide _____

input channel2: Plus \_\_\_ dB, delay \_\_\_ ms, sound silence  on  off, channel click status  on  off

parameter equal filter 1,	filter type _____	centre frequency _____	Q value/wide _____
parameter equal filter 2,	filter type _____	centre frequency _____	Q value/wide _____
parameter equal filter 3,	filter type _____	centre frequency _____	Q value/wide _____
parameter equal filter 4,	filter type _____	centre frequency _____	Q value/wide _____
parameter equal filter 5,	filter type _____	centre frequency _____	Q value/wide _____
parameter equal filter 6,	filter type _____	centre frequency _____	Q value/wide _____
parameter equal filter 7,	filter type _____	centre frequency _____	Q value/wide _____
parameter equal filter 8,	filter type _____	centre frequency _____	Q value/wide _____
parameter equal filter 9,	filter type _____	centre frequency _____	Q value/wide _____
parameter equal filter 10,	filter type _____	centre frequency _____	Q value/wide _____
parameter equal filter 11,	filter type _____	centre frequency _____	Q value/wide _____



Input channel A: Sound source  IN1  IN2  IN1+IN2, output plus \_\_\_ dB  phase  normal  contrary output delay \_\_\_ ms  
 parameter equal filter 1, filter type \_\_\_\_\_ centre frequency \_\_\_\_\_ Q value/wide \_\_\_\_\_  
 parameter equal filter 2, filter type \_\_\_\_\_ centre frequency \_\_\_\_\_ Q value/wide \_\_\_\_\_  
 parameter equal filter 3, filter type \_\_\_\_\_ centre frequency \_\_\_\_\_ Q value/wide \_\_\_\_\_  
 Crossover setting low filter type \_\_\_\_\_ frequency \_\_\_\_\_ low filter type \_\_\_\_\_ frequency \_\_\_\_\_  
 Pressure limit value \_\_\_\_\_ dBFS mute  open  close

Input channel B: Sound source  IN1  IN2  IN1+IN2, output plus \_\_\_ dB  phase  normal  contrary output delay \_\_\_ ms  
 parameter equal filter 1, filter type \_\_\_\_\_ centre frequency \_\_\_\_\_ Q value/wide \_\_\_\_\_  
 parameter equal filter 2, filter type \_\_\_\_\_ centre frequency \_\_\_\_\_ Q value/wide \_\_\_\_\_  
 parameter equal filter 3, filter type \_\_\_\_\_ centre frequency \_\_\_\_\_ Q value/wide \_\_\_\_\_  
 Crossover setting low filter type \_\_\_\_\_ frequency \_\_\_\_\_ low filter type \_\_\_\_\_ frequency \_\_\_\_\_  
 Pressure limit value \_\_\_\_\_ dBFS mute  open  close

Input channel C: Sound source  IN1  IN2  IN1+IN2, output plus \_\_\_ dB  phase  normal  contrary output delay \_\_\_ ms  
 parameter equal filter 1, filter type \_\_\_\_\_ centre frequency \_\_\_\_\_ Q value/wide \_\_\_\_\_  
 parameter equal filter 2, filter type \_\_\_\_\_ centre frequency \_\_\_\_\_ Q value/wide \_\_\_\_\_  
 parameter equal filter 3, filter type \_\_\_\_\_ centre frequency \_\_\_\_\_ Q value/wide \_\_\_\_\_  
 Crossover setting low filter type \_\_\_\_\_ frequency \_\_\_\_\_ low filter type \_\_\_\_\_ frequency \_\_\_\_\_  
 Pressure limit value \_\_\_\_\_ dBFS mute  open  close

Input channel D: Sound source  IN1  IN2  IN1+IN2, output plus \_\_\_ dB  phase  normal  contrary output delay \_\_\_ ms  
 parameter equal filter 1, filter type \_\_\_\_\_ centre frequency \_\_\_\_\_ Q value/wide \_\_\_\_\_  
 parameter equal filter 2, filter type \_\_\_\_\_ centre frequency \_\_\_\_\_ Q value/wide \_\_\_\_\_  
 parameter equal filter 3, filter type \_\_\_\_\_ centre frequency \_\_\_\_\_ Q value/wide \_\_\_\_\_  
 Crossover setting low filter type \_\_\_\_\_ frequency \_\_\_\_\_ low filter type \_\_\_\_\_ frequency \_\_\_\_\_  
 Pressure limit value \_\_\_\_\_ dBFS mute  open  close

Input channel E: Sound source  IN1  IN2  IN1+IN2, output plus \_\_\_ dB  phase  normal  contrary output delay \_\_\_ ms  
 parameter equal filter 1, filter type \_\_\_\_\_ centre frequency \_\_\_\_\_ Q value/wide \_\_\_\_\_  
 parameter equal filter 2, filter type \_\_\_\_\_ centre frequency \_\_\_\_\_ Q value/wide \_\_\_\_\_  
 parameter equal filter 3, filter type \_\_\_\_\_ centre frequency \_\_\_\_\_ Q value/wide \_\_\_\_\_  
 Crossover setting low filter type \_\_\_\_\_ frequency \_\_\_\_\_ low filter type \_\_\_\_\_ frequency \_\_\_\_\_  
 Pressure limit value \_\_\_\_\_ dBFS mute  open  close

Input channel F: Sound source  IN1  IN2  IN1+IN2, output plus \_\_\_ dB  phase  normal  contrary output delay \_\_\_ ms  
 parameter equal filter 1, filter type \_\_\_\_\_ centre frequency \_\_\_\_\_ Q value/wide \_\_\_\_\_  
 parameter equal filter 2, filter type \_\_\_\_\_ centre frequency \_\_\_\_\_ Q value/wide \_\_\_\_\_  
 parameter equal filter 3, filter type \_\_\_\_\_ centre frequency \_\_\_\_\_ Q value/wide \_\_\_\_\_  
 Crossover setting low filter type \_\_\_\_\_ frequency \_\_\_\_\_ low filter type \_\_\_\_\_ frequency \_\_\_\_\_  
 Pressure limit value \_\_\_\_\_ dBFS mute  open  close

Output channel click status: \_\_\_\_\_  
 \_\_\_\_\_

Other setting:

The panel operation is locked or not \_\_\_\_\_ machinery address code \_\_\_\_\_  
 machinery information \_\_\_\_\_  
 \_\_\_\_\_

# 13> BLOCK DIAGRAM

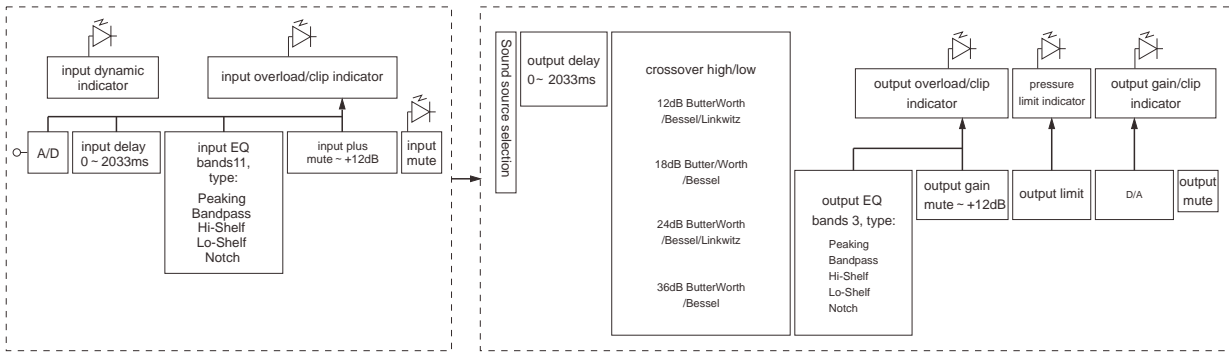
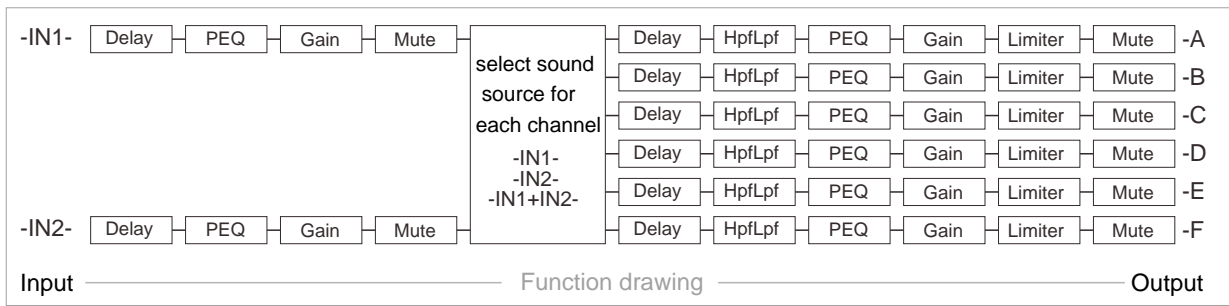

# 14> Dimensions

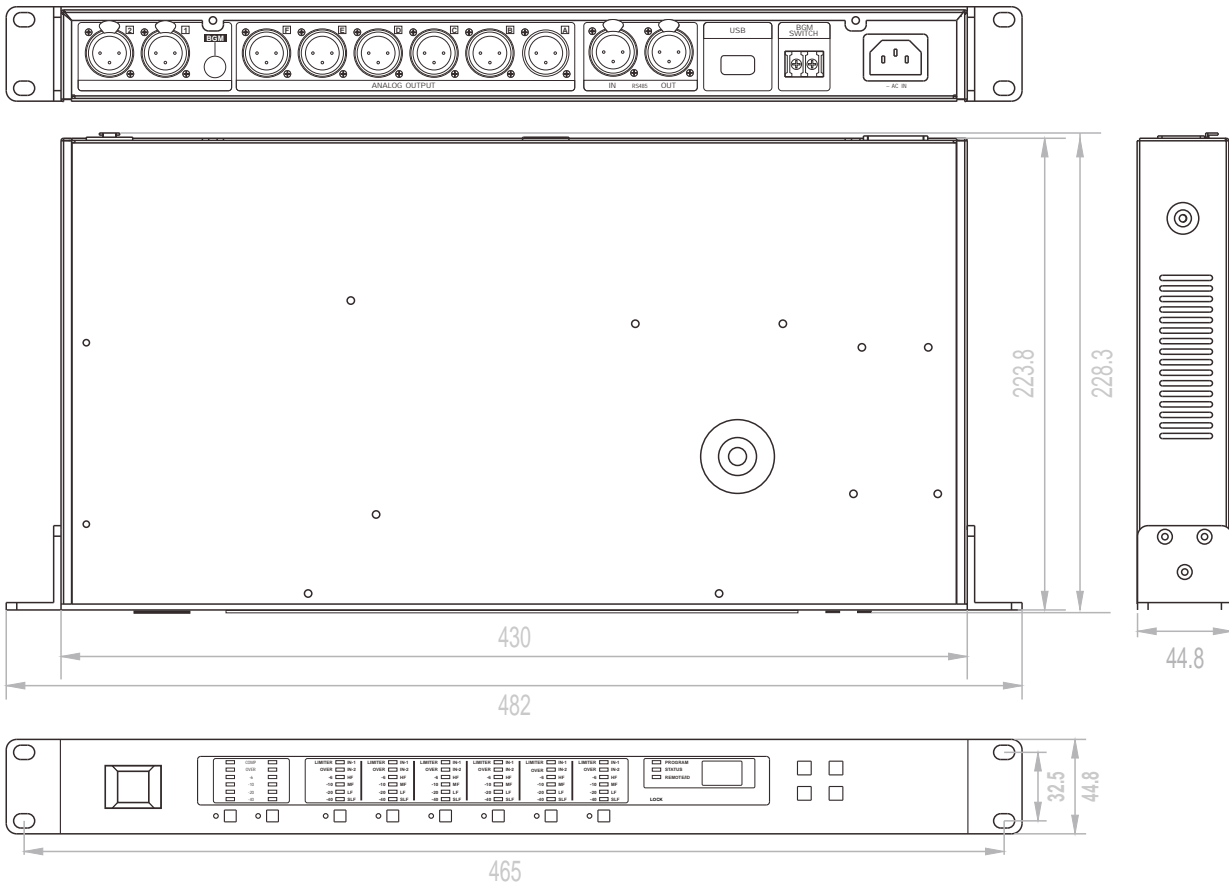



User Manual

**ΣC-2600U**  
DIGITAL SPEAKER PROCESSOR

[www.elderaudio.com](http://www.elderaudio.com)