



Beta Three

CL110

10" 3-Transducer 2-Way Full Range Speaker
CL Series Medium Line Array System

User Manual

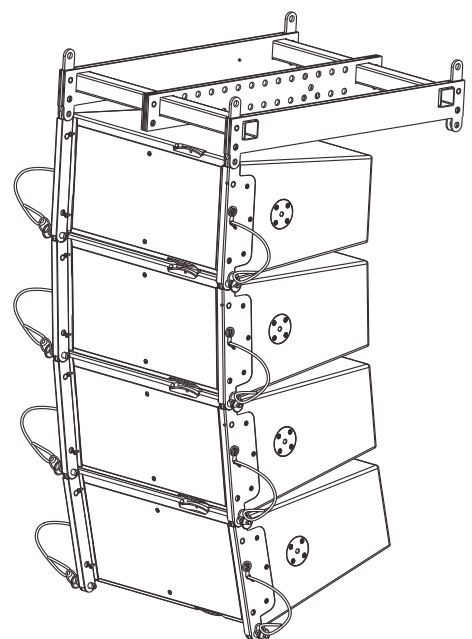
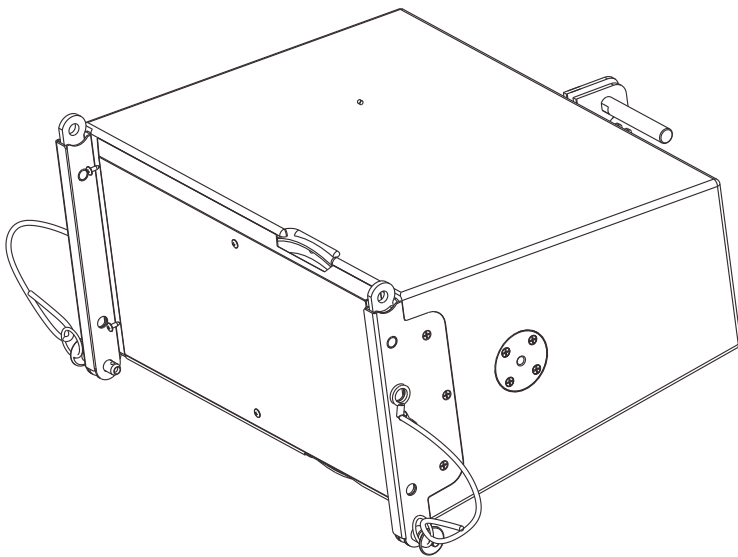



UM-CL110-20090618 ver A



SAFETY INSTRUCTIONS

PLEASE READ THIS MANUAL FIRST

Thank you for a buying β_3 product. Read this manual first as it will help you operate the system properly. Please keep this manual for future reference.

⚠ WARNING: *This product must be installed by professionals. When using hanging brackets or rigging other than those supplied with the product, please ensure they comply with the local safety codes.*

	CAUTION RISK OF ELECTRICAL SHOCK DO NOT OPEN	
CAUTION: TO REDUCE THE RISK OF ELECTRIC SHOCK, DO NOT REMOVE COVER (OR BACK). NO USER-SERVICABLE PARTS INSIDE. REFER SERVICING TO QUALIFIED PERSONNEL.		

	AVIS RISQUE DE CHOC ÉLECTRIQUE NE PAS OUVRIR	
ATTENTION : POUR RÉDUIRE LE RISQUE DE DÉCHARGE ÉLECTRIQUE, NE RETIREZ PAS LE COUVERCLE (OU L'ARRIÈRE). IL NE SE TROUVE À L'INTÉRIEUR AUCUNE PIÈCE POUVANT ÊTRE RÉPARÉE PAR L'USAGER. S'ADRESSER À UN RÉPARATEUR COMPÉTENT.		



The exclamation point within an equilateral triangle is intended to alert you to the presence of important operating and servicing instructions.



ATTENTION: *Don't refit the system or spare parts without being authorized as this will void the warranty.*



WARNING: *Don't place naked flames (such as candles) close to the equipment.*

1. Read the instruction manual first before using this product.
2. Please keep this manual for future reference
3. Pay attention to all warnings.
4. Obey all operating instructions.
5. Do not expose this product to rain or moisture.
6. Clean this equipment with a dry cloth.
7. Do not block any ventilation openings. Install according to manufacturer's instructions .
8. Do not install this product near any heat source, such as a, heater, burner, or any other equipment with heat radiation .
9. Only use spare parts supplied by the manufacturer.
10. Pay attention to the safety symbol on the outside of the cover.



CONTENT

PRODUCT INTRODUCTION	3
Main Features	3
Product Description	3
Applications	3
CONNECTION	4
Push Terminals	4
NI4 Connection	4
System Connection Example	4
INSTALLATION	5
Installation Guidance	5
APPLICATION	6
Medium Point Source Application	6
Large Point Source Application	6
Line Array Application	6
Line Array Connection Guide	7
TECHNICAL SPECIFICATIONS	8
Specifications	8
Frequency Response And Impedance Curve	8
Dimensions	9

 Product information may be updated without notification, please visit www.elderaudio.com for the latest update.

CL110

10"2-Way Full Range Speaker

Main Features

- CL110 is a set of medium full range speakers in the CL Array Series. It is composed of one 10" neodymium LF transducer and two 1.7" HF transducers, with built-in crossover.
- Dispersion 120° x 30° at 1kHz
- Sensitivity 95 dB, Max SPL 118 dB.
- RMS Power 200W, Peak Power 800W.
- T shape cabinet structure, easy installation and uninstallation with lockpins, 5° adjustable cabinet angle range.
- 4xCL110 and 1xCL212B make up an excellent point source system.
- With the customized hanging wares, the system can be used both for hanging and be put on the ground.
- The sound produced by R12 is clear powerful and elastic.

Product Description

CL110 is a set of medium full range speakers in the CL Line Array Series. It is composed of 1 x 10" neodymium LF transducer and 2 x 1.7" HF Transducer, with built-in crossover. The LF transducer is made from 65mm voice coil. The HF frequency upper limit is set at 3kHz, with 95 dB sensitivity and 120 x 30 dispersion angle.

Advanced spraying technique is used in the T shape cabinet of CL110. The adjustable angle range of the cabinet is 5°. Installation and uninstallation is easy with the lockpins. The dispersion angle of a single CL110 is 120°x 30°. In application of multiple CL110, the vertical dispersion is 90°x 10°; the transmission distance gets farther.

The LF transducer of CL110 is made from 65mm big power flat aluminum wire voice coil, whose frame is made from high intensity Kapton material. Thus the power endurance capacity is strengthened and the sensitivity of the transducer is heightened.

The RMS power of CL110 is 200W, and the peak power is 800W (GB/T9396 Standard). The sensitivity of a single CL110 is 95dB.

The cabinet of CL110 is made from 15mm plywood. The wedge structure frees the cabinet of any nails. The surface is coated with high wear-resistant paints. The design of rigging methods is so reasonable that it can free the cabinet from outside force. The pulling resistance of the rigging accessories is 7 times higher than required. (45000N)

Thanks to the Q235 material and the powder spraying techniques, the grill of CL110 has high intensity and high salt mist resistance. In the atmosphere of 5% sodium hydroxide, it has salt mist resistance duration of 96 hours. In actual application it can keep itself rust free for 5 years. The inner side of the grill is padded with cottons to protect it from rains.

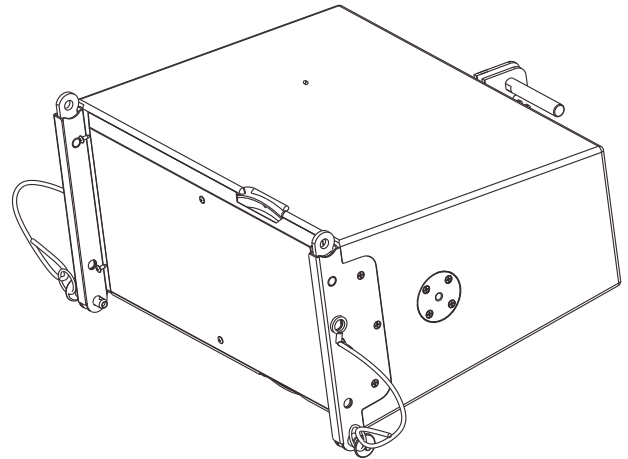

CL110 is mainly designed to reduce disturbance to the fullest extent and enhance the sound quality. In CL110 we fully abide by the line array design patterns. When the length of the combination has reached 7 meters, the system can meet the reinforcement requirement of line array system, especially for human voice.

The HF transducer of CL110 is made from 34mm flat aluminum voice coil, titanium diaphragm, and the patent wave guide and horn. The sound performance is extraordinary.

CL110 is mainly applied in meeting rooms, large multifunction halls, auditorium, churches and mobile performance.

Applications

- Multi-function hall
- Auditorium
- Religion Place
- All kinds of living performance
- Assembly room

Two NL4 connectors are available for amplifier connections. Paralleled connector is very convenient for another speaker connection.

Speakon

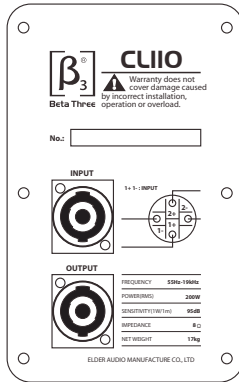

1+ 1- INPUT

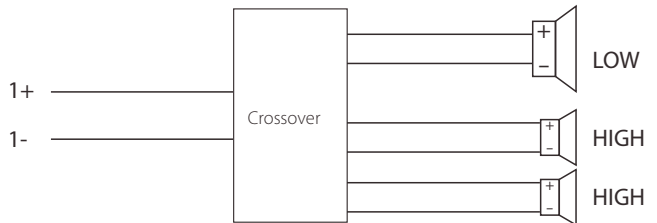

NL4 Wiring Connection

1. Connect

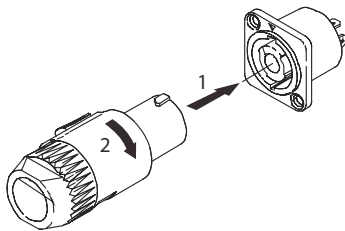

2. Disconnect

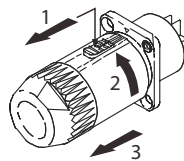

System Connection Reference

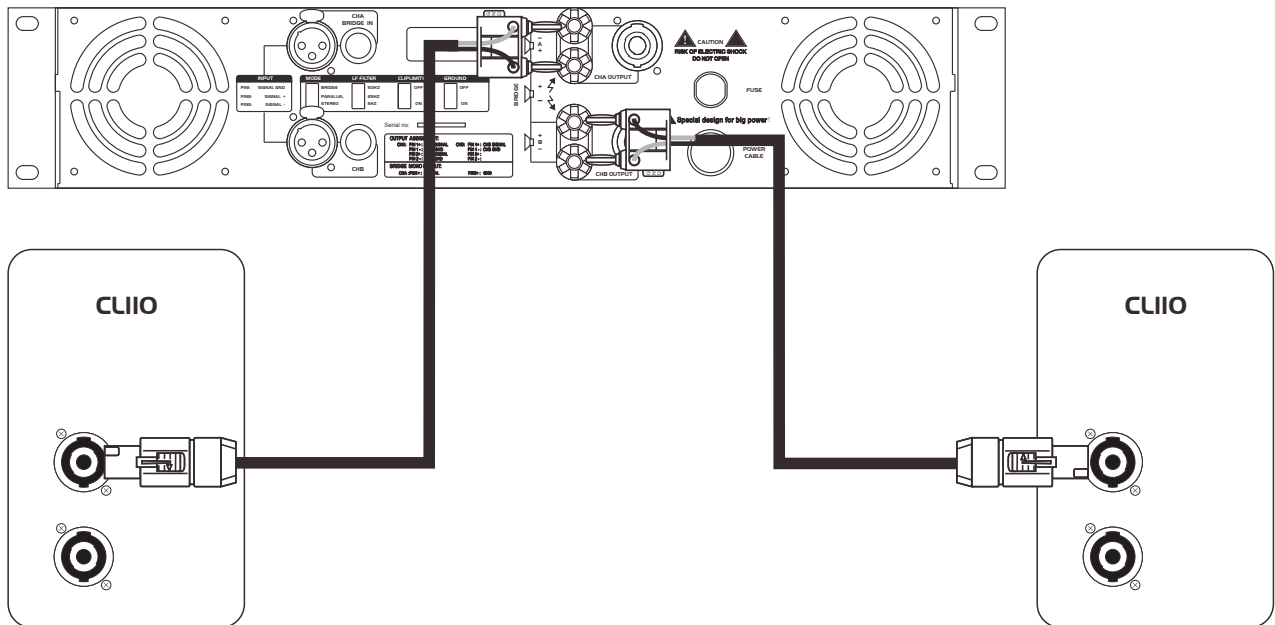

Warning: Please make sure the speaker impedance and polarity match the amplifiers.

Installation Guidance

- (1) CL110 has customized hanging wares for convenient and easy hanging and installation.
- (2) CL110 can be used individually, and can also be used with CL212B to form a line array system.
- (3) The hanging wares include CL212B hanging bracket, CL110 cabinet front and rear hanging ware and the lockpins.
- (4) The rear hanging ware is fixed on the cabinet for easy and fast field vertical angle adjustment between the speakers.
- (5) The hanging frame of CL212B is a welding steel frame, which can hang multiple CL110. But optional accessories are provided according to actual requirements.

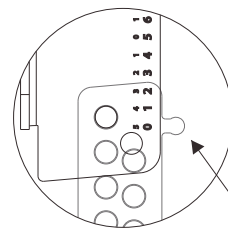
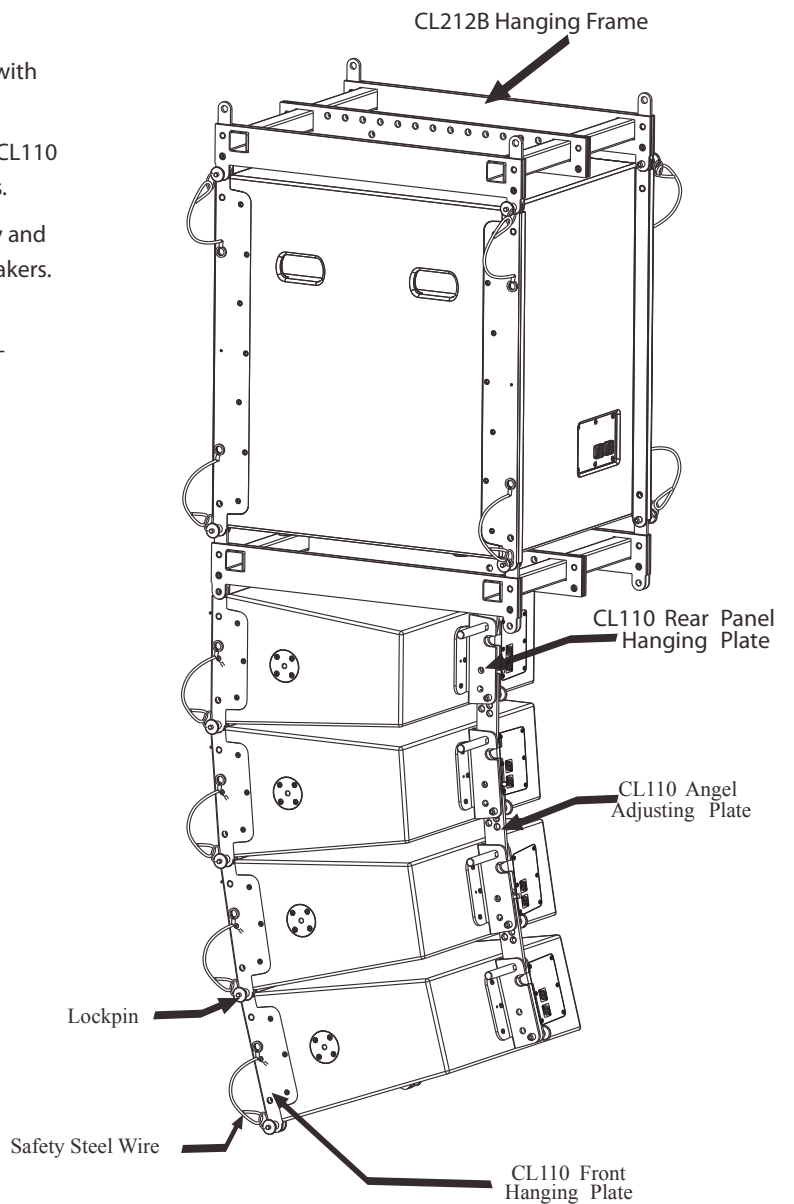
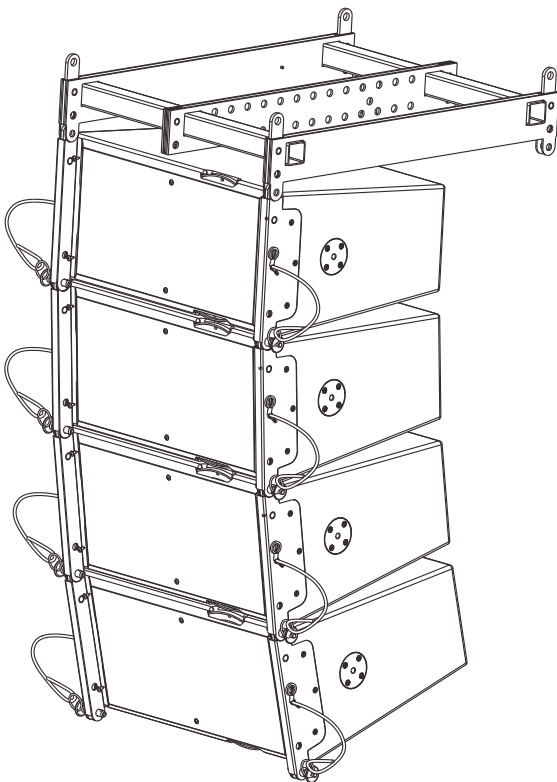

Warning: Make sure the mounting accessories safety factor not less than 5:1 or meet the local standard during installation.

The number rear hanging plate indicates the current angle. E.g. 1 means that the angle between 2 CL110 is 1.

1. Medium Point Source Application

A. Hand up

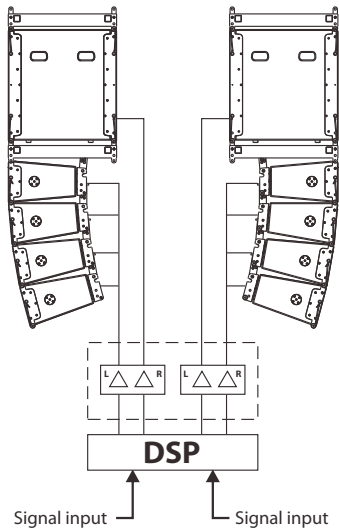

B. Put in the floor

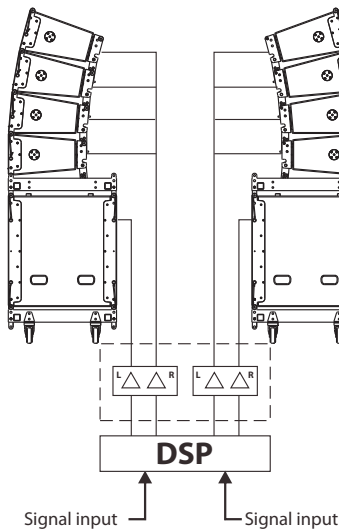

2. Large Point Source Application

A. Hand up

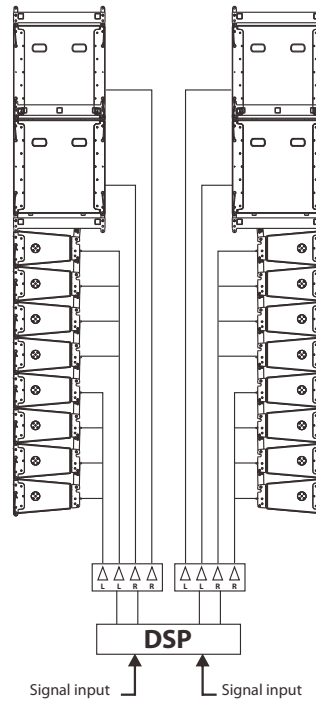

B. Put in the floor

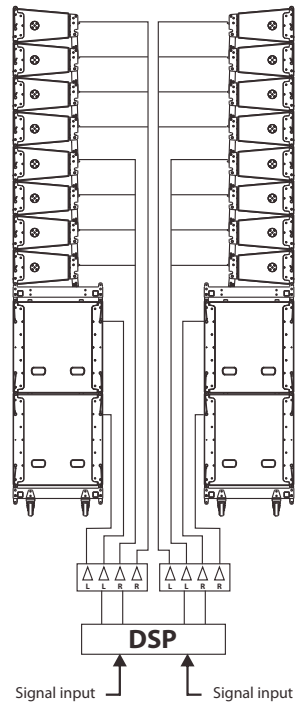

Coverage features of Line Array System

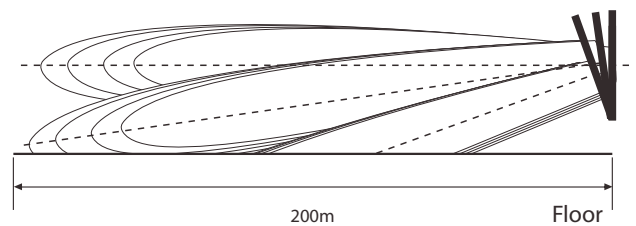

Warning: Make sure the mounting accessories safety factor not less than 5:1 or meet the local standard during installation .

Line Array Connection Guide

CL110 has built-in crossover, you only need to connect the amplifier with suitable power to the DSP control, and adjust the crossover point at 160Hz, and the system works.

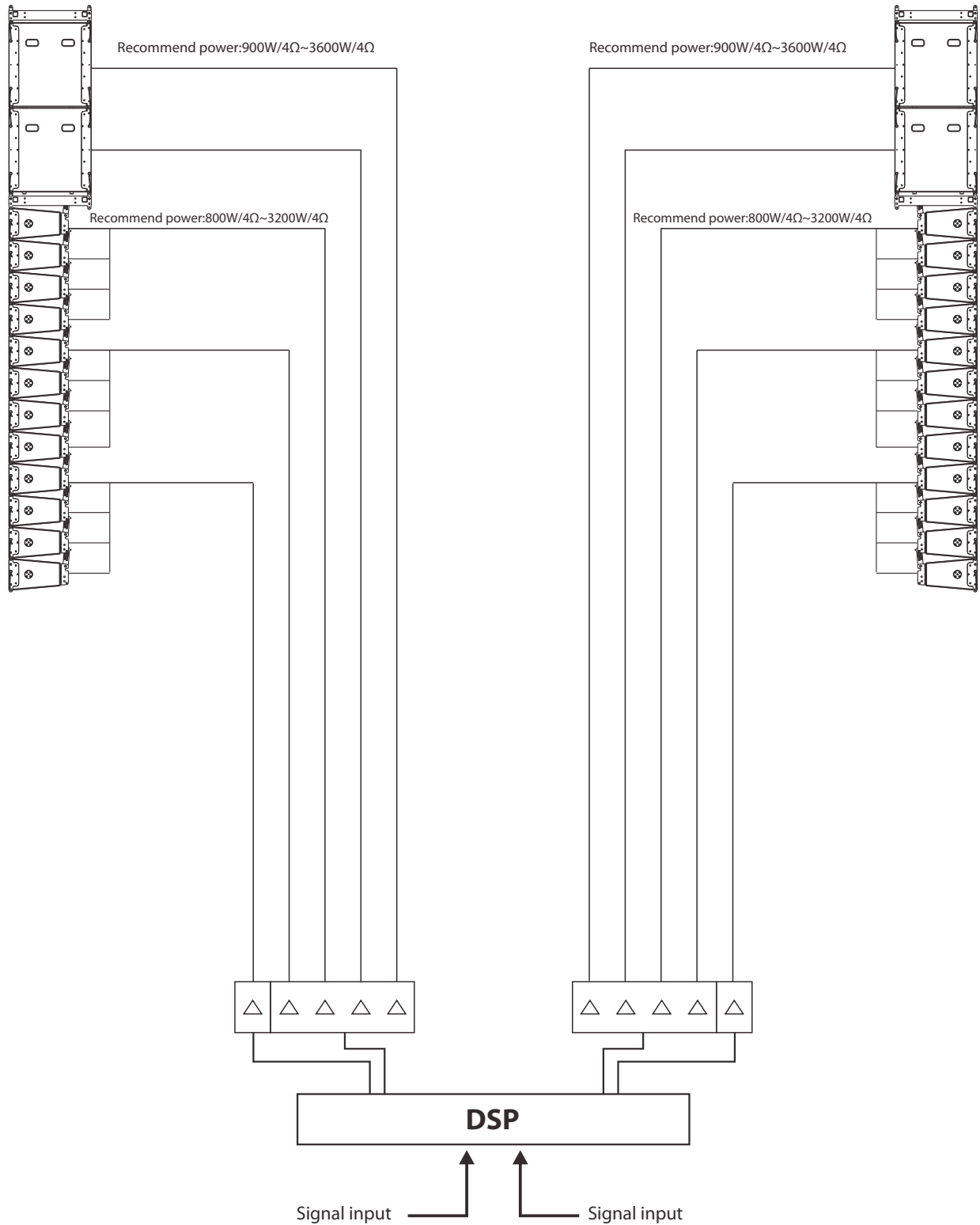

CL110 Specifications

Product:	Passive Paint Wooden Full Range Speaker
HF Driver:	2w T44 HF Compression driver
LF Driver:	1 X 10" LF Drivers
Frequency Response(-3db):¹	55Hz-19kHz
Frequency Response(-10db):	45Hz-20kHz
Sensitivity(1w@1m):²	95dB
Maximum. Spl(1m):³	118dB/124dB(PEAK)
Power:⁴	200W (RMS) 400W (MUSIC) 800W (PEAK)
Dispersion(HxV):	120t w 30t
Rated Impedance:	8 ohms
Crossover point:	3kHz
Cabinet:	Trapezoidal cabinet ,15mm Plywood
Installation:	Specialized hardware
Paint:	Black Polyurethane painting for cabinet & Black Powder coated grille
Connector:	NI4 x 2
Dimension(W x H x D):	538.5 x 262 x 434.5mm (21.2 x 10.3 x 17.1in)
Packing Dimension(W x H x D):	630 x 595 x 380mm (24.8 x 23.4 x 15.0in)
Net Weight:	17.0kg(37.4 lb)
Gross Weight:	18.5kg(40.7 lb)
Optional Accessories:	Specialized suspension frame

Speaker Testing Method

1. Frequency Response

Use pink noise to test the speaker in the anechoic chamber, adjust the level to make the speaker work at its rated impedance and set the output power at 1W, then test the frequency response 1m away from the speaker.

2. Sensitivity

Use full range Pink noise which has been modified using an EQ curve to test the speaker in the anechoic chamber, increasing the signal to make the speaker work at its rated impedance and set the power output at 1W, then test the sensitivity 1m away from the speaker.

3. MAX.SPL

Use full range Pink noise which has been modified using an EQ curve to test the speaker in the anechoic chamber, increase the signal to make the speaker work at its maximum power output level, then test the SPL1m away from the speaker.

4. Rated Power

Use pink noise to the IEC#268-5 standard to test the speaker, increase the signal for a continuous period of 100 hours, the rated Power is the power when the speaker will show no visible or measurable damage.

Technical Specifications

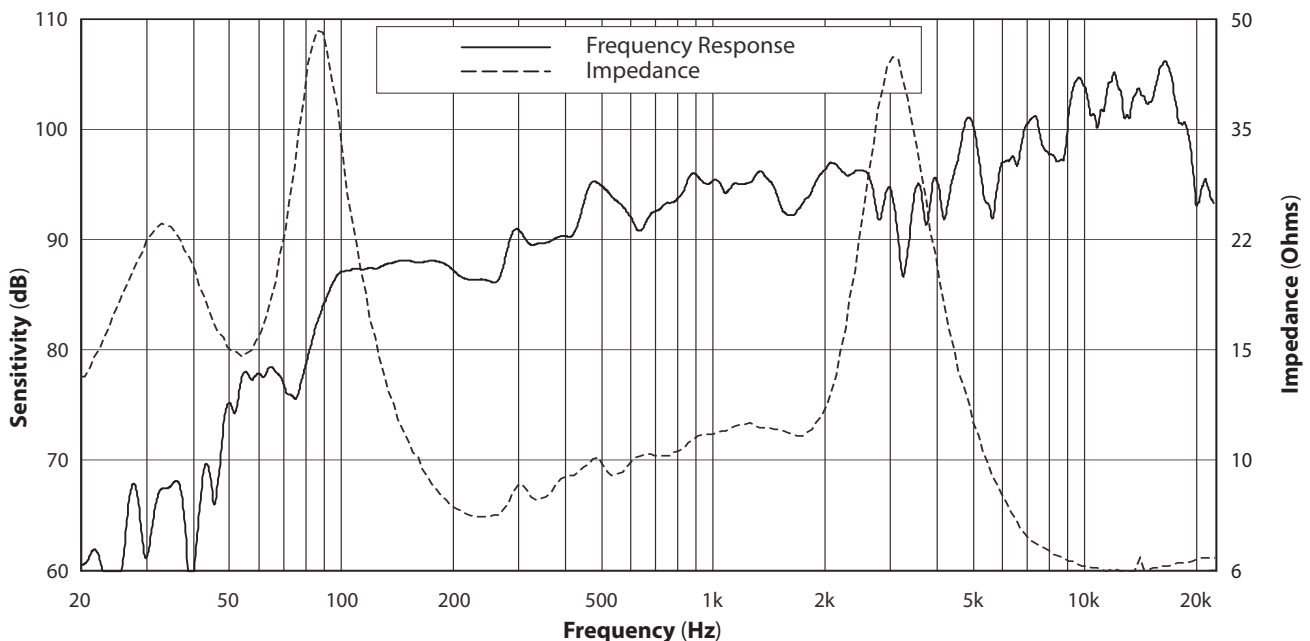

Dimensions

Top view

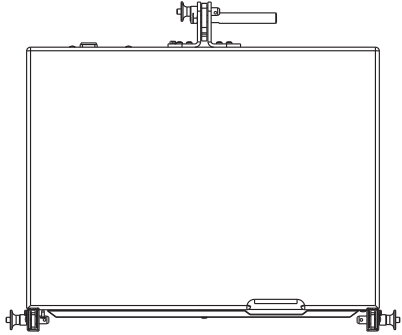

Front view

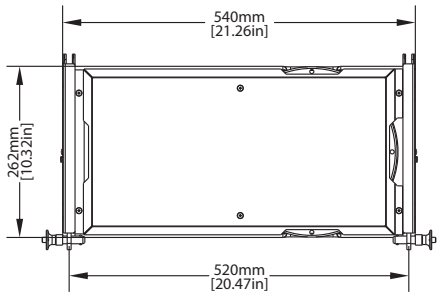

Side view

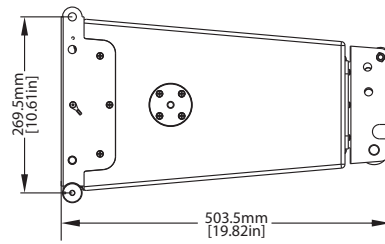

Back view

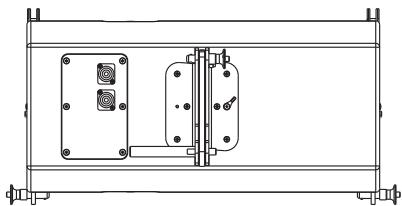

Notes:



Beta Three