



Beta Three

CSR212A

THEATER SURROUNDING SPEAKER

USER'S MANUAL

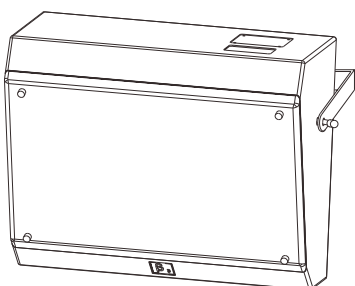

ED-B3-MA-051111-002



Features :

- **Two transducers two way phase-inversed surrounding cinema speaker, professional high efficient transducers. Computer simulating design.**

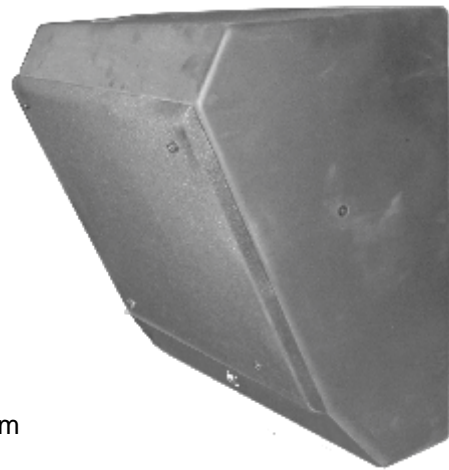

- Two transducers two way full range
- High SPL, high sensitivity
- One 12" big power woofer
- One compression driver with 44mm titanium diaphragm
- Built-in electronic protection crossover
- (50-100)° x 55° wide dispersion can get the wider covering
- Computer simulating design provide very good Frequency response and phase feature
- Very convenient walling installation mode
- Suitable for THX, DTS and other multi-channel surrounding sound reinforcement in cinema
- Suitable for big/mid cinema audio system
- Can work with A3 CSB218A, CS3412A, CS3415A when used for high quality music replaying

Specifications :

Transducers	Bass: 12" x 1 ; Treb :1 .7" x 1
Frequency response(-3dB/-10dB)	55Hz-20KHz/42Hz-20KHz
Sensitivity(1m/1W)	94dB
Xover point	2.2KHz
Dispersion(H x V)	50°-100° x 55°
Amplifier power output :	300W
Rated impedance	8 Ohm
DC impedance	5.6 Ohm
THD	<3%
Input	Spring clip
Net weight	18.5Kg
Gross weight	23Kg
Dimensions(W x D x H)	625 x 273 x 405mm
Packing dimensions(W x D x H)	495 x 391 x 705mm

Cabinet Dimension :

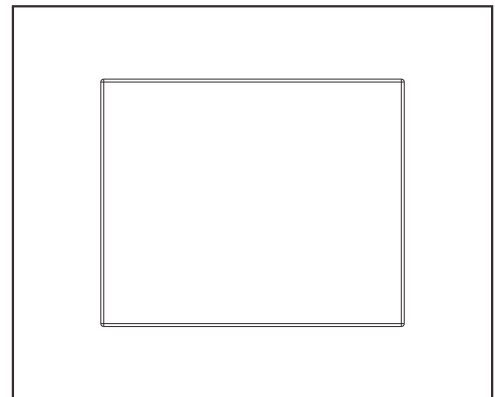
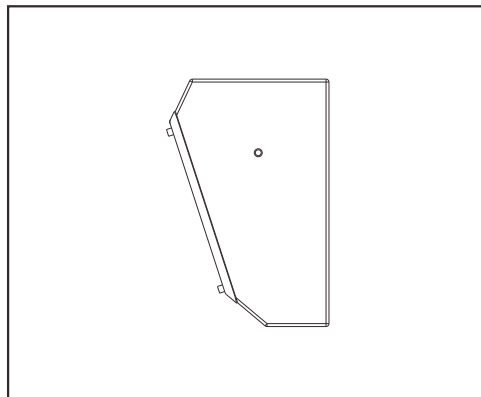
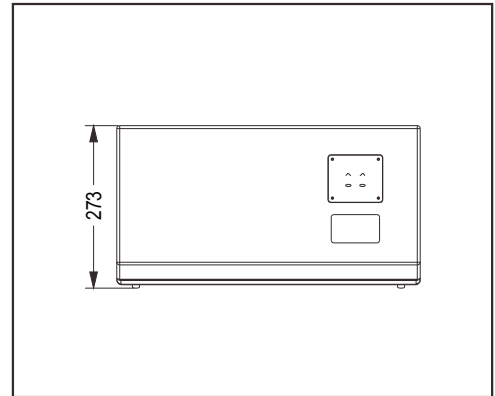
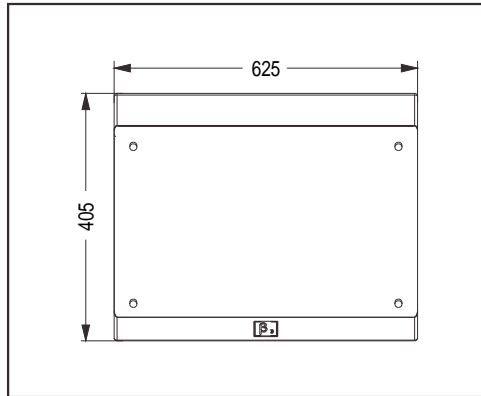

Installation drawing :

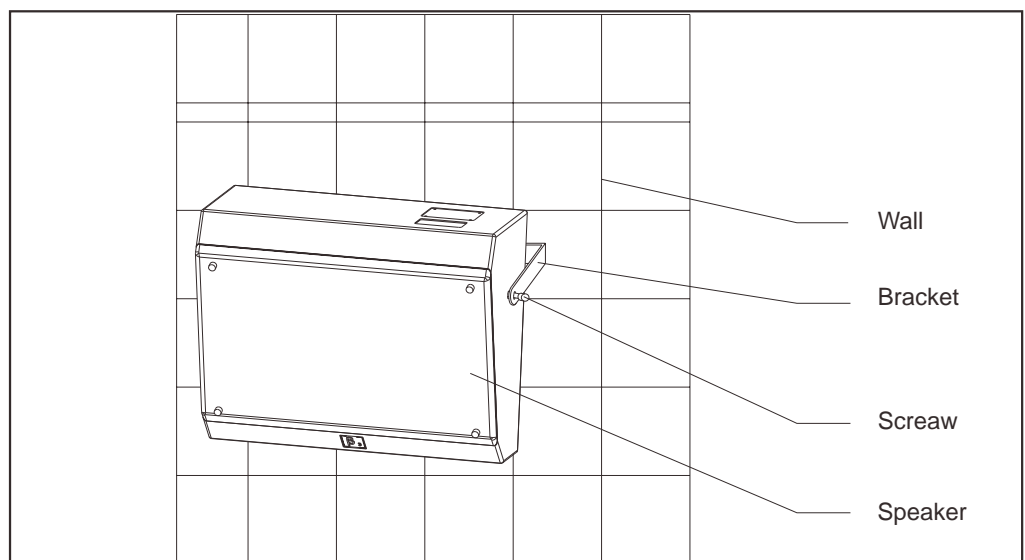

CSR212A
THEATER SURROUNDING SPEAKER