

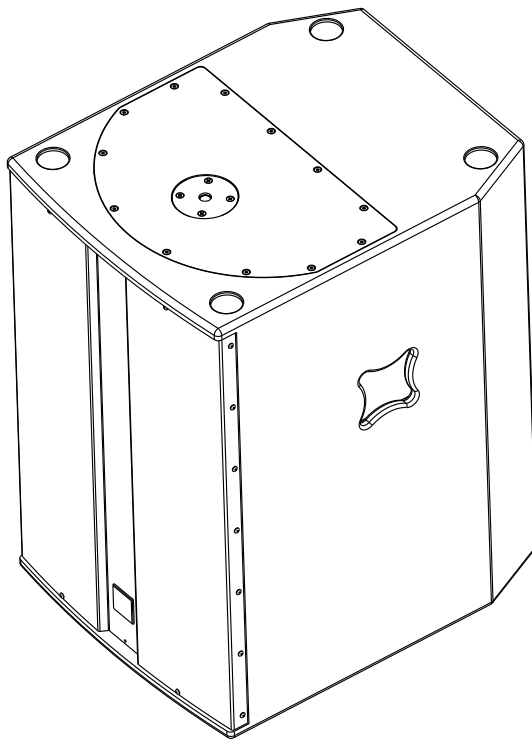

Beta Three

ΣΗ118B





CONTENTS

PRODUCT FEATURES	-----	1
SPECIFICATION	-----	1
ACOUSTIC CHARTS	-----	2
DIMENSIONS	-----	4
LIMITED WARRANTY	-----	5

H118B

PRODUCT FEATURES

- H118B is the foldaway horn loaded speaker with big power and high sensitivity. Because of the foldaway horn, it can reproduce the lower LF musical signal with smaller volume, meanwhile the SPL will be 3dB higher than normal phase-inverted speaker.
- High intensity plywood cabinet is strong enough, also can absorb the noise caused by resonance.
- Multifunctional connection way can meet the different applications. Corresponding connection design avoid the connection mistake during the application.
- 18" woofer with 100mm V.C adopt the 220mm big magnet, power can reach 800W, high SPL, excellent reliability.
- Can be used as the main sound reinforcement system with 3 215H.

SPECIFICATION

Transducers	LF:18' x 1
Frequency Response(-3dB)	65Hz-200Hz
Sensitivity(1m/1W)	99dB
SPL(1m):	131dB
Max.SPL(1m):	137dB
Power(RMS)	800W
Power(Program)	1600W
Power(Peak)	3200W
Rated Impedance	8
DC Impedance	5.4
THD	<3%
Input Connectors	NL4 x 4 , 1+ 1- 2+ 2-
Net Weight	52.0kg
Gross Weight	58.0kg
Dimensions (W x D x H)	550 x 680 x 800mm
Packing Dimensions(W x D x H)	780 x 660 x 970mm

H118B

FREQUENCY RESPONSE

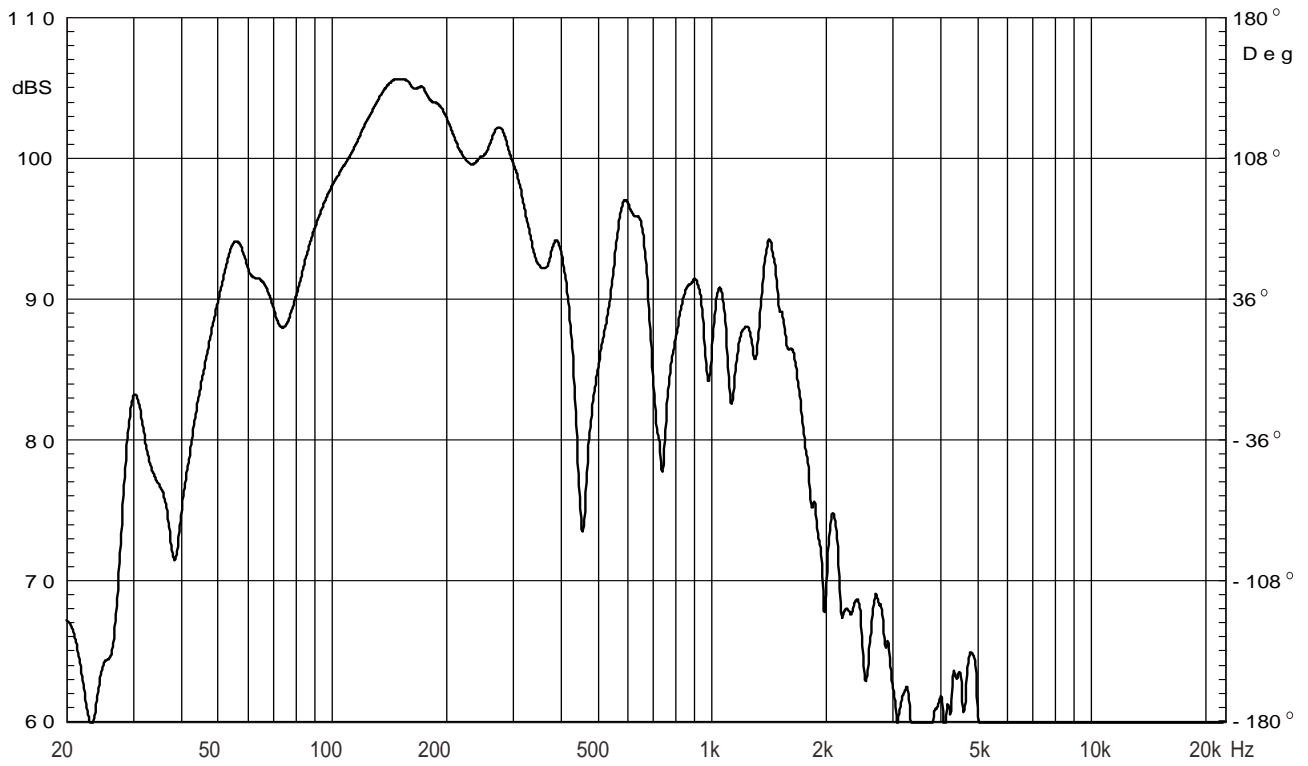

IMPEDANCE RESPONSE

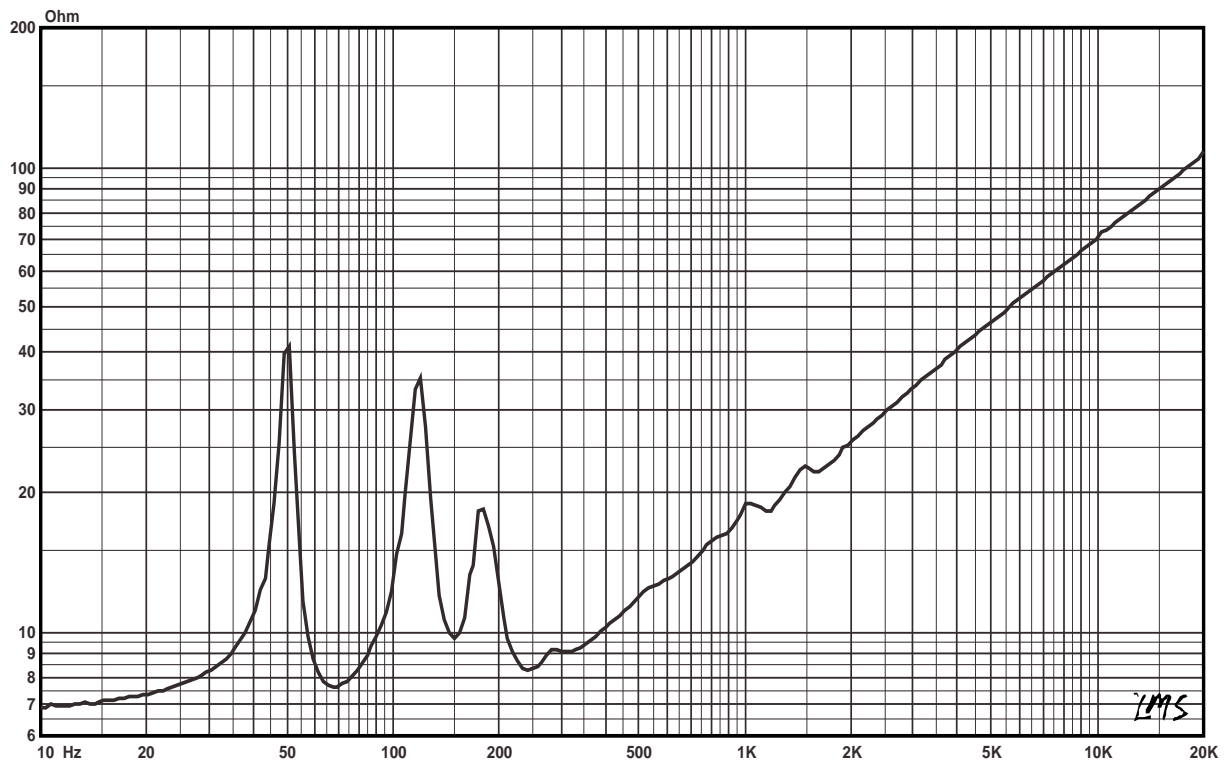

H118B

WATERFALL

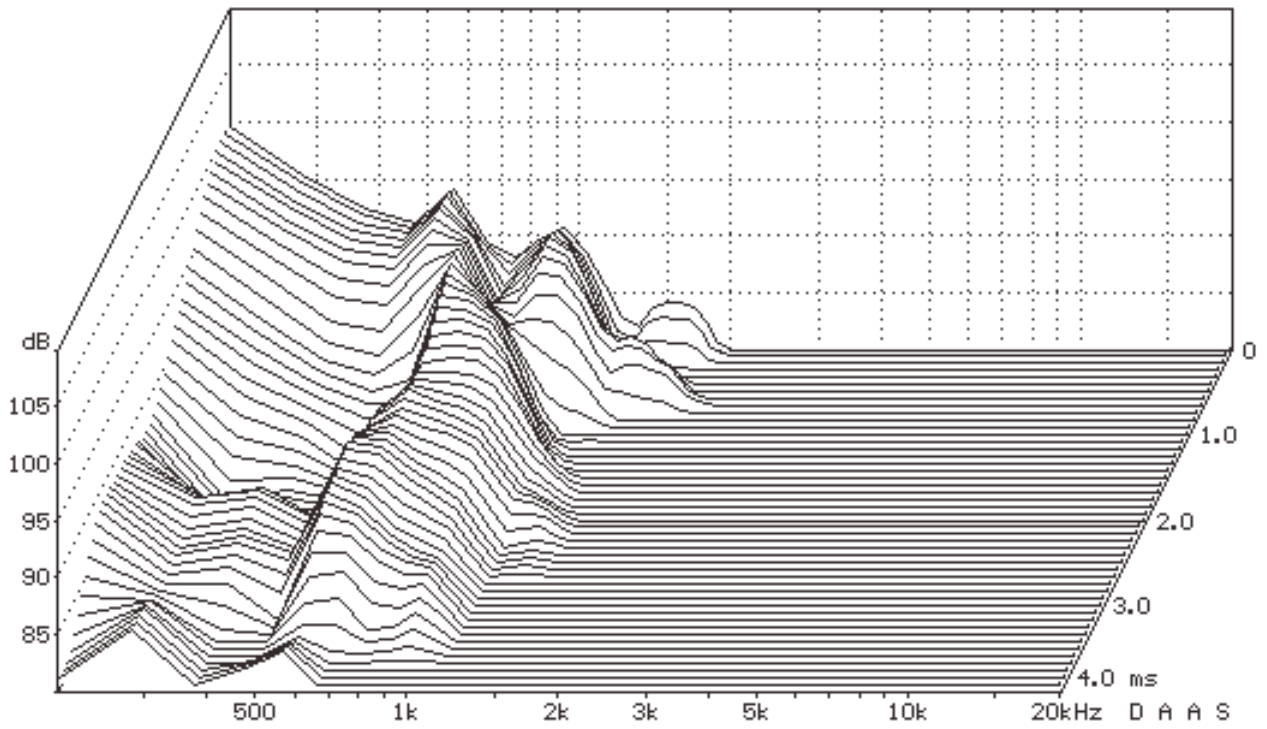

THD

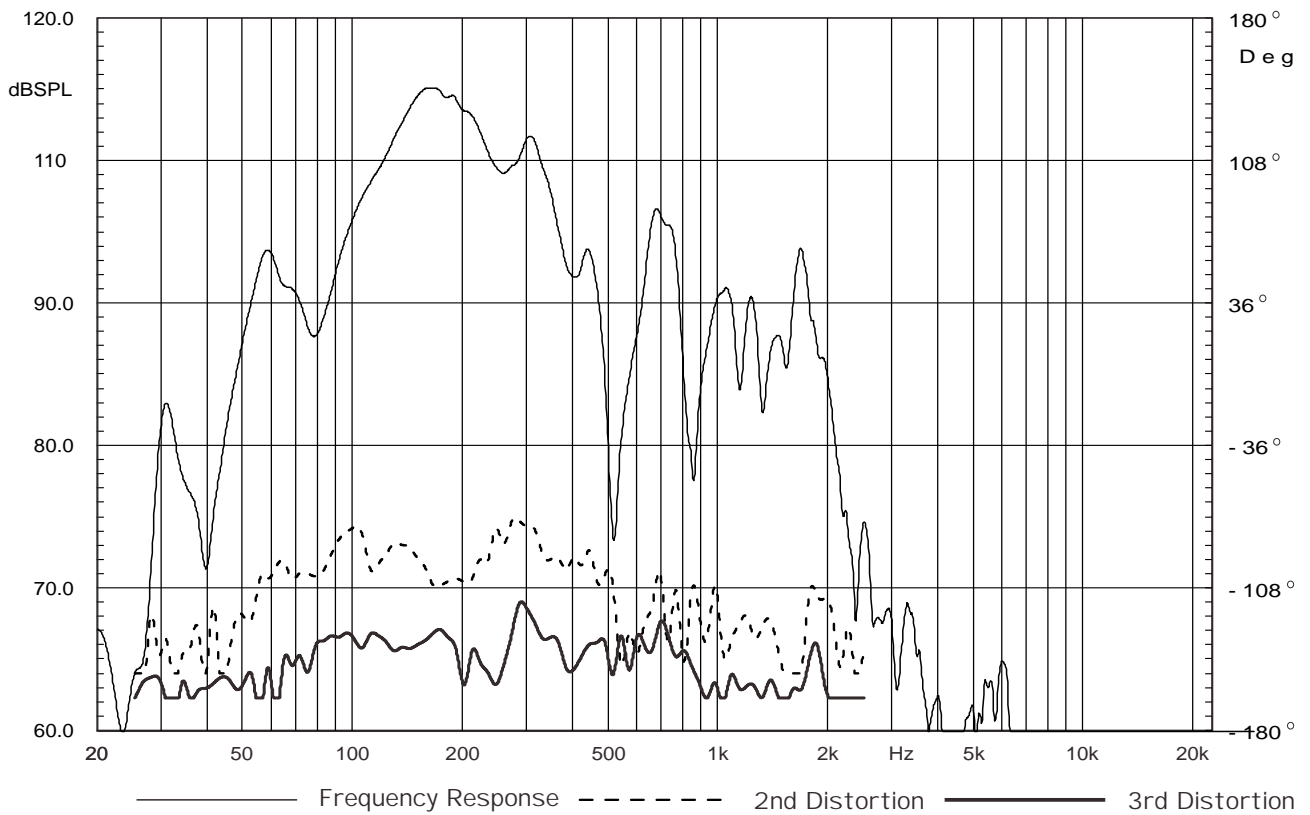

H118B

DIMENSION

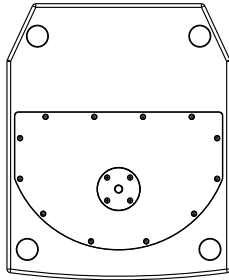

Top View

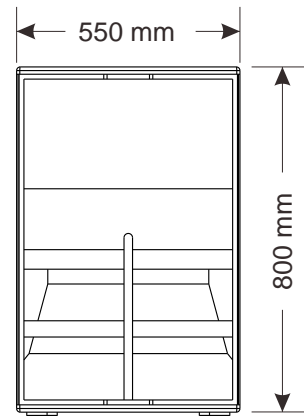

Front View

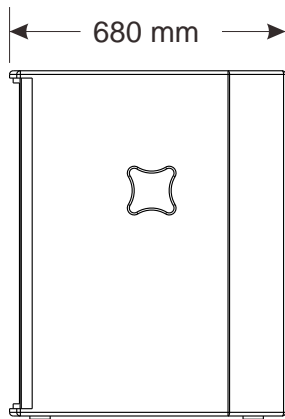

Side View

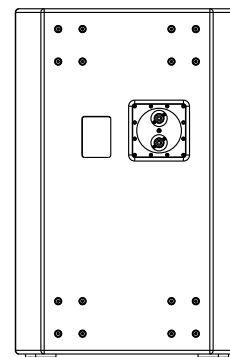

Back View

H118B

LIMITED WARRANTY

If malfunction occurs during the specified warranty period from the date of original purchase, the product will be repaired or replaced without charge by Elder Audio.

The Limited Warranty does not apply to:

- (a) exterior finish or appearance;
- (b) certain specific items described in the individual product data sheet or owner's manual;
- (c) malfunction resulting from use or operation of the product other than as specified in the individual product data sheet or owner's manual;
- (d) malfunction resulting from misuse or abuse of the product;
- (e) malfunction occurring at any time after repairs have been made to the product by anyone other than Elder Audio Service or any of its authorized service representatives.

To obtain warranty service, customer must deliver proof of purchase of the product in the form of a bill of sale or receipt invoice.

¶H118B Speakers and Speaker Systems are guaranteed against malfunction due to defects in materials or workmanship for a period of three (3) years from the date of original purchase. The Limited Warranty does not apply to burned voice coils or malfunctions such as cone and/or coil damage resulting from improperly designed enclosures. Additional details are included in the

Limited Warranty statement.

¶H118B Accessories are guaranteed against malfunction due to defects in materials or workmanship for a period of one (1) year from the date of original purchase. Additional details are included in the Limited Warranty statement.

¶H118B Flying Hardware (including enclosure-mounted hardware and rigging accessories) is guaranteed against malfunction due to defects in materials or workmanship for a period of one (1) year from the date of original purchase. Additional details are included in the Limited Warranty statement.

Specifications are subject to change without notice.



Beta Three

H118B