



Beta Three

T15

Two Way 15" Full Range
Passive Speaker

THUNDER Series Pro Loudspeaker System

User Manual

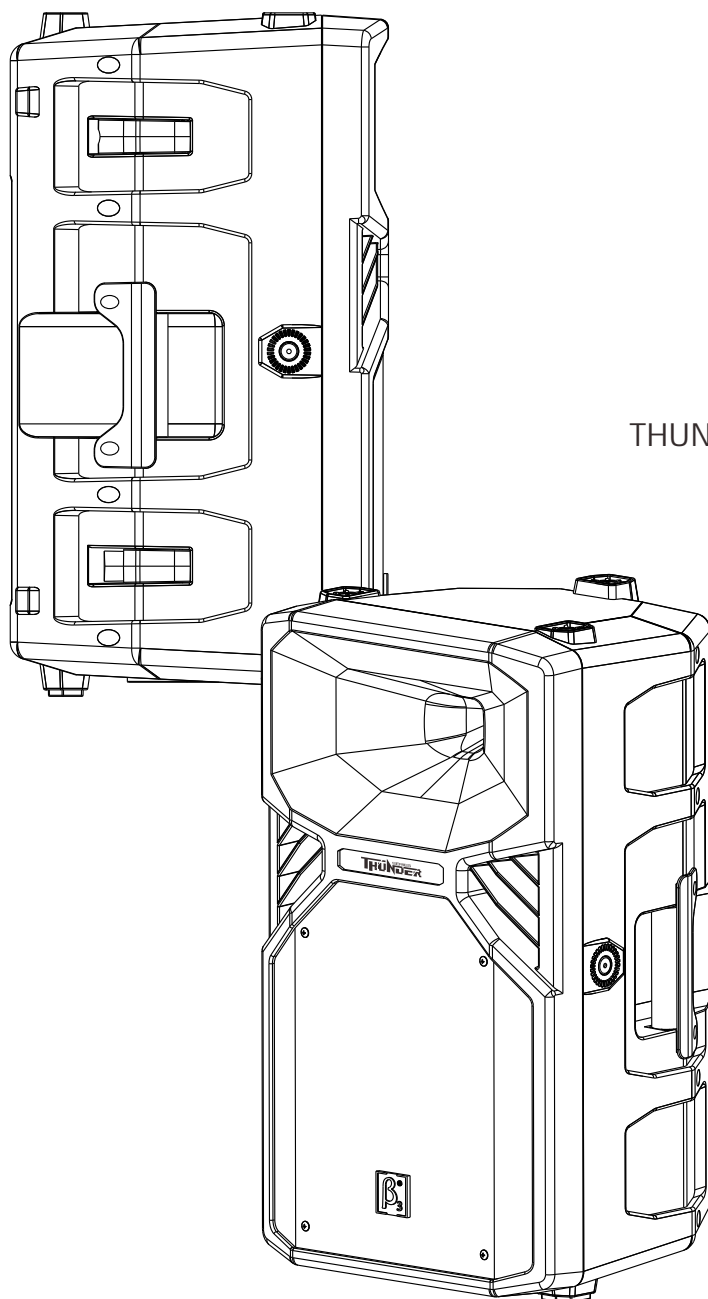



UM-T15-20120905 ver B



SAFETY INSTRUCTIONS

PLEASE READ THIS MANUAL FIRST

Thank you for a buying β_3 product. Read this manual first as it will help you operate the system properly. Please keep this manual for future reference.

⚠ WARNING: *This product must be installed by professionals. When using hanging brackets or rigging other than those supplied with the product, please ensure they comply with the local safety codes.*

	CAUTION RISK OF ELECTRICAL SHOCK DO NOT OPEN	
CAUTION: TO REDUCE THE RISK OF ELECTRIC SHOCK, DO NOT REMOVE COVER (OR BACK). NO USER-SERVICABLE PARTS INSIDE. REFER SERVICING TO QUALIFIED PERSONNEL.		

	AVIS RISQUE DE CHOC ÉLECTRIQUE NE PAS OUVRIR	
ATTENTION : POUR RÉDUIRE LE RISQUE DE DÉCHARGE ÉLECTRIQUE, NE RETIREZ PAS LE COUVERCLE (OU L'ARRIÈRE). IL NE SE TROUVE À L'INTÉRIEUR AUCUNE PIÈCE POUVANT ÊTRE RÉPARÉE PAR L'USAGER. S'ADRESSER À UN RÉPARATEUR COMPÉTENT.		

 *The exclamation point within an equilateral triangle is intended to alert you to the presence of important operating and servicing instructions.*

⚠ ATTENTION: *Don't refit the system or spare parts without being authorized as this will void the warranty.*

⚠ WARNING: *Don't place naked flames (such as candles) close to the equipment.*

1. Read the instruction manual first before using this product.
2. Please keep this manual for future reference
3. Pay attention to all warnings.
4. Obey all operating instructions.
5. Do not expose this product to rain or moisture.
6. Clean this equipment with a dry cloth.
7. Do not block any ventilation openings. Install according to manufacturer's instructions .
8. Do not install this product near any heat source, such as a, heater, burner, or any other equipment with heat radiation .
9. Only use spare parts supplied by the manufacturer.
10. Pay attention to the safety symbol on the outside of the cover.

CONTENT

INTRODUCTION	3
Features	3
Description	3
Applications	3
CONNECTION	4
2 x NL4	4
NL4 Connection	4
System Connection Reference	4
INSTALLATION	5
Mounting Accessories	5
Installation Reference	5
TECHNICAL SPECIFICATION	6
Technical Sheet	6
Frequency Response and Impedance Curve	6
2D Dimension	7

T15

Two Way 15" Full Range Passive Speaker

Features

- Compact lightweight design with unique appearance.
- Heavy duty powered coated steel grill.
- 35mm SMART pole mount for vertical and 5 downward tilt.
- Integrated feet for stage monitor applications.
- M8 rigging points for convenient installation.

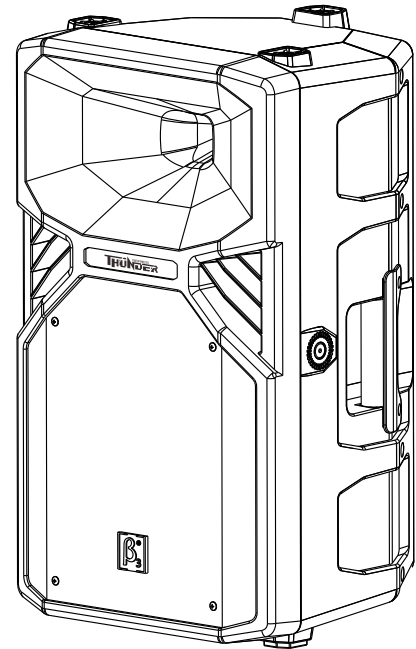

Description

T15 Thunder series is designed for portable and installed applications. The integrated polymer PVC cabinet design ensures durability and full natural high performance sound.

Beta Three T15 is a full range with a high powered 15" woofer delivering powerful low frequency and the 1.7" Titanium compression driver delivering high definition mid/high frequencies.

Rigging points and SMART pole mount makes for easy installation or portable use.

Applications

- Church
- Auditorium
- Conference room
- Small performance
- Multifunctional hall

Two NL4 connectors are located on the rear panel for power amplifier connection and parallel connection to another speaker.

2 × NL4 :

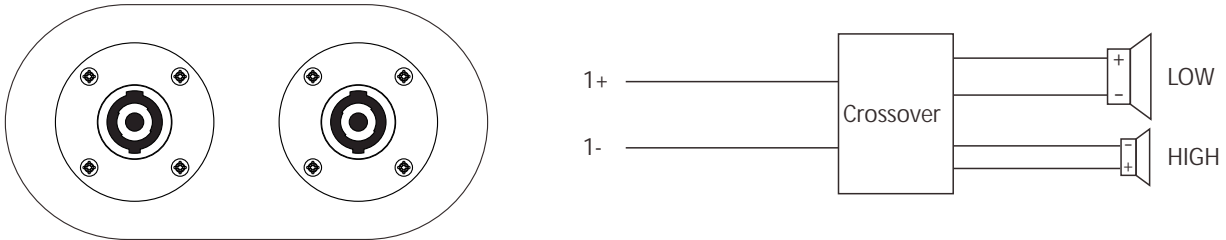

NL4 Connection

1. Connect

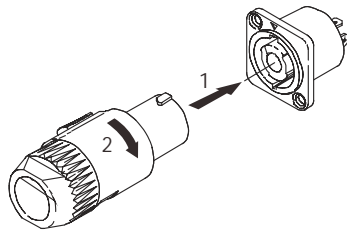

2. Disconnect

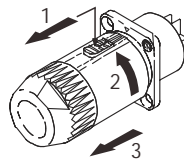

System Connection Reference

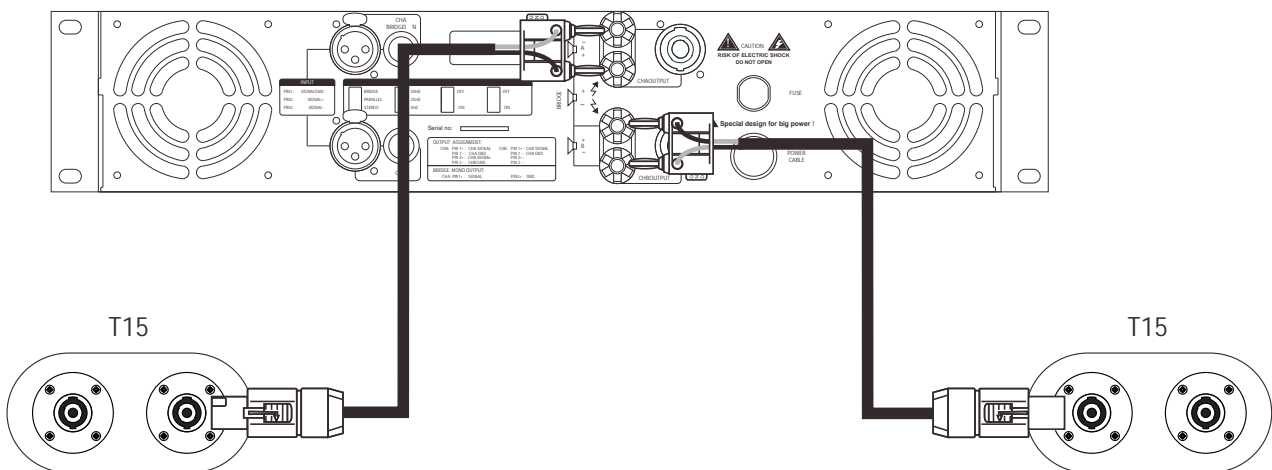

- ⚠ **Attention:** The impedance of connected speaker must match the impedance of amplifier output.
- ⚠ **Attention:** Make sure the polarity of speaker and amplifier are correct .

Installation Accessories(Optional)

1. Speaker stand



2. U-Bracket

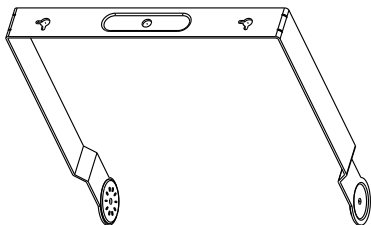

Warning: Make sure the mounting accessories safety factor not less than 5:1 or meet the local standard during installation .

Installation Reference

1.Reference A

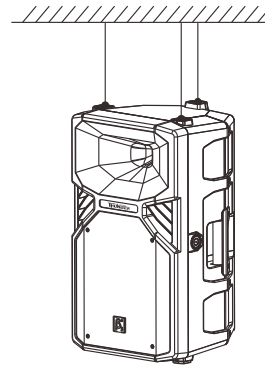

2.Reference B

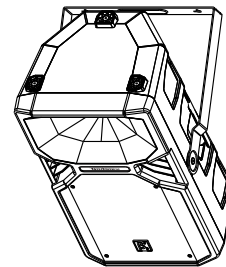

3.Reference C

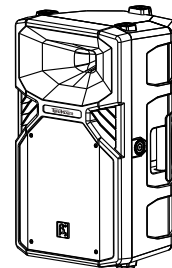

4.Reference D

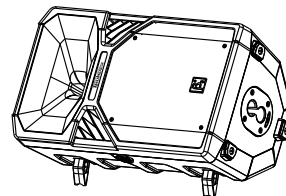

5. Speaker stand application

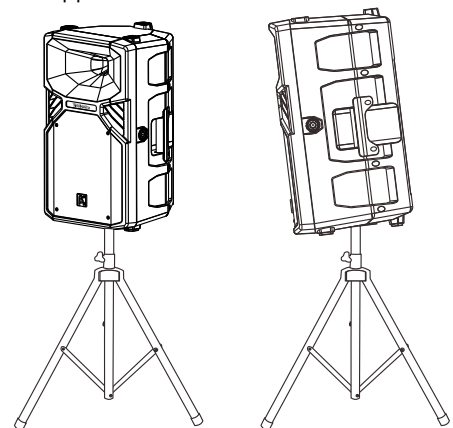

Technical Specification

System:	Two Way 15" Full Range Passive Speaker
System components:	1 x 15" LF, 1 x 1.7" HF
Frequency response(-3dB): ¹	45Hz-17kHz
Frequency response(-10dB):	40Hz-18kHz
Sensitivity(1W@1m): ²	96dB
Max. SPL(1m): ³	119dB/125dB(PEAK)
Power:	300W (RMS) ⁴ 600W (MUSIC) 1200W (PEAK)
Rated impedance:	8 Ohms
Dispersion(H x V):	90 ° x 60 °
Cabinet:	Polypropylene injection moulding
Mounting accessories:	8 x M8 hanging point, SMART pole mount system
Handle:	Two side, one rear
Painting:	Powered coated grill
Connector:	NL4 x 2
Cabinet dimension: (W x D x H)	462 x 397 x 780mm (18.2 x 15.6 x 30.7in)
Package dimension: (W x D x H)	528 x 480 x 865mm (20.8 x 18.9 x 34.1in)
Net weight:	26.8kg(59.0 lb.)
Gross weight:	28.5kg(62.7 lb.)
Optional accessory:	U-Bracket

Speaker Testing Method

1. Frequency Response

Use Pink noise to test the speaker in the anechoic chamber, adjust the level to make the speaker work at its rated impedance and set the output power at 1W, then test the frequency response 1m away from the speaker.

2. Sensitivity

Use full range Pink noise which has been modified using an EQ curve to test the speaker in the anechoic chamber, increasing the signal to make the speaker work at its rated impedance and set the power output at 1W, then test the sensitivity 1m away from the speaker.

3. MAX.SPL

Use full range Pink noise which has been modified using an EQ curve to test the speaker in the anechoic chamber, increase the signal to make the speaker work at its maximum power output level, then test the SPL 1m away from the speaker.

4. Rated Power

Use Pink noise to the IEC#268-5 standard to test the speaker, increase the signal for a continuous period of 100 hours, the rated power is the power when the speaker will show no visible or measurable damage.

Frequency response curve & Impedance curve

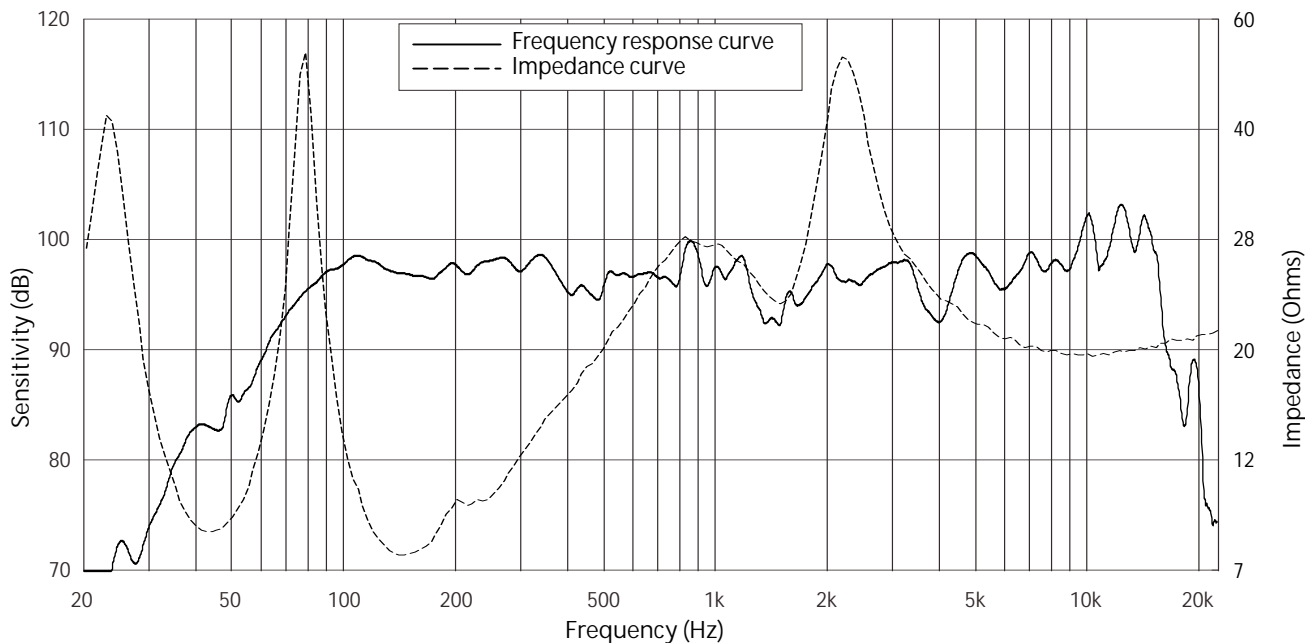

2D Dimension

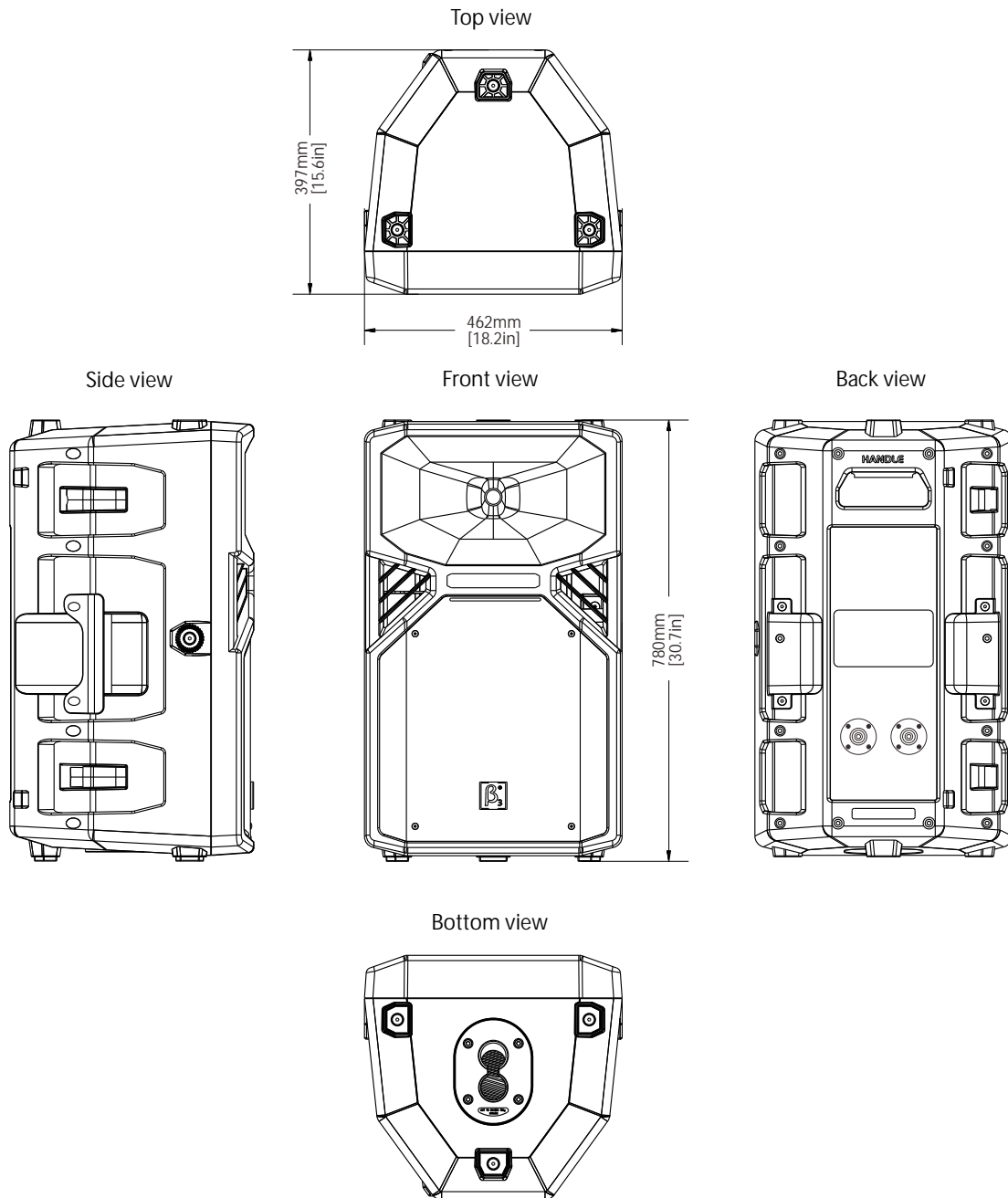

Notes:



Beta Three